

## **EFPF: European Connected Factory Platform for Agile Manufacturing**



European Factory  
Platform

### **WP4: Development of EFPF Building Blocks**

### **WP5: EFPF Add-ons**

## **D5.11: EFPF Matchmaking and Intelligence Gathering**

### **Vs: 1.0**

**Deliverable Lead and Editor:** Happy Dudee, VLC

**Contributing Partners:** SRFG, CERTH, VLC, AID, C2K, ICE

**Date:** 2020-06-30

**Dissemination:** Public

**Status:** <Draft | Consortium-Approved | EU Approved>

#### **Short Abstract**

This deliverable presents an account of developments achieved under Matchmaking and Intelligence gathering tasks in EFPF project. This is an interim report which details the vision, methodology and the state of the art as of M18 of the project. Finally, a plan of future work describes the work beyond M18.

Grant Agreement:  
825075



## Document Status

<b>Deliverable Lead</b>	Happy Dudee, VLC
<b>Internal Reviewer 1</b>	Alexander Schneider, FIT
<b>Internal Reviewer 2</b>	Carolyn Langen, ALM
<b>Type</b>	Deliverable
<b>Work Package</b>	WP 4: Development of EFPF Building Blocks WP 5: EFPF Add-ons
<b>ID</b>	D5.11: EFPF Matchmaking and Intelligence Gathering
<b>Due Date</b>	2020-06-30
<b>Delivery Date</b>	2020-06-30-30
<b>Status</b>	<Draft   Consortium Approved   EU Approved>

## History

See Annex A.

## Status

This deliverable is subject to final acceptance by the European Commission.

## Further Information

[www.efpf.org](http://www.efpf.org)

## Disclaimer

The views represented in this document only reflect the views of the authors and not the views of the European Union. The European Union is not liable for any use that may be made of the information contained in this document.

Furthermore, the information is provided “as is” and no guarantee or warranty is given that the information is fit for any particular purpose. The user of the information uses it at its sole risk and liability.

## Project Partners:



## Executive Summary

This deliverable presents the overall architecture as well as progress made in two tasks of EFPF project:

T4.5: Matchmaking and Agile Network Creation

T5.1: Business and Network Intelligence Gathering and Propagation

The section on matchmaking introduces the reader to the matchmaking approach being taken in the EFPF project. It continues to bring out the four layers of matchmaking being implemented in this task. Federated search is one of the most important functionalities in this project as it allows the user to simultaneously query all connected databases making this a powerful feature for matchmaking.

An account of federated search is presented along with its history of development all the way to the state of the art. Different approaches for implementing federated search are also discussed and the reason for choosing the appropriate search mechanism (index-time merging) is explained too.

Subsequent sections explain individual indexing workflows of constituent platforms. The report discusses the need for a common manufacturing ontology and presents a snapshot of the ontology that is developed and being used in this project. The second part of the matchmaking task is the implementation of a recommendation system which will predict and present the users with relevant recommendations based on their searches. A high-level design on the proposed recommendation system has been discussed along with some discussion on results obtained currently. The section ends with a description of pilot use case which addresses the automated matchmaking during online bidding in the Circular Economy scenario by partner KLEEMAN.

Business and Network Intelligence (B&NI) section introduces the reader to the wider understanding of intelligence in the industry and explains the context of this service inside EFPF ecosystem. The report also explains the different services made available and their relation to other EFPF components. The B&NI module is divided into three sections by application. All tools and services that enable organisations to generate intelligence from their internal operations such as shop floor production, sales activities, project management etc. are grouped under the category 'Intracompany Level Intelligence Service'.

Moving beyond the boundaries of an organisation, the tools and services that help manufacturers explore and exploit intelligence from their existing networks (industry associations, supply chain networks, digital platforms) are grouped under the category 'Platform/Network Level Intelligence Services'. Within this category, a new service has been introduced which collects network movement on the EFPF portal and presents users with opportunity to use that in decision making. To read more about this service please go to section – Platform & Network Intelligence Solution.

The third category is to do with mining intelligence beyond your known existing network such as the wider industry or the region manufacturer is based in. This service is being developed by task partners as a need was felt to provide openly available intelligence, usually dispersed around the web in different sources, directly to the user's disposal. Please see section – 'Market Intelligence Services'. Two pilots are being carried out with project partners to test these services as well as share these as case studies for other

adopters. The report ends with concluding note that surfaces the close connection in these two tasks and provides a window view into the planned next phase of the project.

## Table of Contents

0	Introduction .....	1
1	Matchmaking .....	4
1.1	Introduction.....	4
1.2	Federated Search.....	4
1.2.1	Federated Search Problems.....	5
1.2.2	State of the art.....	5
1.2.3	Federated Search Approaches.....	6
1.3	Design of Federated Search and Recommendation Mechanisms in EFPF.....	9
1.3.1	Federated Search.....	9
1.3.2	EFPF Manufacturing Ontology .....	11
1.3.3	EFPF Matchmaking Data Flows .....	14
1.3.4	Indexing Workflows.....	15
1.3.5	COMPOSITION Data Indexing Workflow .....	15
1.3.6	SMECluster Data Indexing Workflow.....	17
1.3.7	NIMBLE Data Indexing Workflow .....	18
1.3.8	Recommendation Service.....	18
1.3.9	Discussion of the Current Results .....	20
1.4	Matchmaking Services for Automated Online Bidding.....	22
1.4.1	Problem Statement.....	22
1.4.2	State-of-the-art .....	23
1.4.3	Design of the Semantic Matchmaker.....	24
2	Business and Network Intelligence Gathering and Propagation .....	29
2.1	Introduction – Data, analytics and Intelligence .....	29
2.2	Scope and Relationship with other EFPF components.....	31
2.3	Requirements .....	33
2.4	Tools and Services .....	35
2.4.1	Intracompany Level Intelligence Services.....	36
2.4.2	Platform/Network Level Intelligence Services.....	37
2.4.3	Market Intelligence Services.....	52
2.5	Execution and Pilot Case Studies.....	54
2.5.1	Hanse Aerospace .....	54
2.5.2	AIDIMME .....	57
2.6	Limitations .....	61
2.7	Further Developments .....	61
2.7.1	Intracompany Level Intelligence Services.....	62
2.7.2	Platform & Network Level Intelligence Services .....	62
2.7.3	Market Intelligence Services.....	62
3	Conclusion.....	63
	Annex A: History .....	65
	Annex B: References.....	66

## 0 Introduction

### 0.1 EFPF Project Overview

EFPF – European Connected Factory Platform for Agile Manufacturing – is a project funded by the H2020 Framework Programme of the European Commission under Grant Agreement 825075 and conducted from January 2019 until December 2022. It engages 30 partners (Users, Technology Providers, Consultants and Research Institutes) from 11 countries with a total budget of circa 16M€. Further information: [efpf.org](http://efpf.org)

In order to foster the growth of a pan-European platform ecosystem that enables the transition from “analogue-first” mass production, to “digital twins” and lot-size-one manufacturing, the EFPF project will design, build and operate a federated digital manufacturing platform. The Platform will be bootstrapped by interlinking the four base platforms from FoF-11-2016 cluster funded by the European Commission, early on. This will set the foundation for the development of EFPF Data Spine and the associated toolsets to fully connect the existing platforms, toolsets and user communities of the 4 base platforms. The federated EFPF platform will also be offered to new users through a unified Portal with value-added features such as single sign-on (SSO), user access management functionalities to hide the complexity of dealing with different platform and solution providers.

### 0.2 Deliverable Purpose and Scope

The purpose of this document “D5.11 Matchmaking and Intelligence Gathering”, is to present an overview of matchmaking services and well as business and network intelligence gathering services in the EFPF project. This deliverable articulates the vision behind introduction and continuous development of these services as well as their benefits to prospective users. The scope of this deliverable includes presenting an account of the progress made since project start, state of the art and planned future developments to the reader. The report also aims to bring out the close relationship between these two services and explain the interdependencies between them.

This is an interim report presented at M18 (month 18) milestone into a 48-month project. therefore, the deliverable presents the current status of these services and constituent solutions. These will be developed further along the course of the project and updates on the progress as well as results will be reported through “D5.14 Matchmaking and intelligence Gathering – Final Report”.

### 0.3 Target Audience

The target audience for this document are all parties that are interested in understanding matchmaking and intelligence components of EFPF ecosystem. This includes project partners who would like to collaborate or contribute to the development of these solutions or simply get a better understanding of them. This also includes external readers who are interested in following the developments taking place in EFPF project with respect to these two components (including open call participants who might be interested in using these services as part of their open call project).

In addition, this deliverable provides the European Commission (including appointed Independent experts) with an overview of the matchmaking and intelligence components of the EFPF platform.

## 0.4 Deliverable Context

This document is one of the cornerstones for achieving the project results. Its relationship to other documents is as follows:

- **D2.1: Project Vision and Roadmap for Realising Integrated EFPF Platform:** Provides an overview of the EFPF project and platform
- **D3.11: EFPF Data Spine Realisation:** Provides an overview of the data spine architecture necessary to understand dependencies and component relationships.
- **D5.13: EFPF Interfacing, Evolution and Extension:** Provides an overview of the ecosystem creation and the evolving nature of this unified platform.
- **D5.12: EFPF Security and Governance:** Provides an overview of the portal which acts as an access point for using these services as well as data protection policies being developed/adopted in the project.

## 0.5 Document Structure

This deliverable is broken down into the following chapters:

- **Section 1: Matchmaking** – Provides an overview of the Matchmaking services available to federated ecosystem.
- **Section 2: Business and Network Intelligence Gathering and Propagation** – Provides an overview of the business and networking intelligence solutions made available to the federated ecosystem.
- **Section 3: Conclusion** – Provides conclusion to the progress discussed in both chapters and explains the closeness between them.

### Annexes:

- **Annex A:** Document History
- **Annex B:** References

## 0.6 Document Status

This document is listed in the Description of Action (DoA) as “public” post recent amendments. It presents the description of tools and solutions provided by the EFPF platform under matchmaking and intelligence services. The document can be used especially by external entities to understand their function and further utilise them through the portal.

## 0.7 Document Dependencies

This document is first part of two deliverables that describe ‘matchmaking’ and ‘business and network intelligence’ components of the EFPF platform. This first version is submitted as an interim report in Month 18 of the project. The second and final iteration will be presented in Month 48 as the final report.



## **0.8 Glossary and Abbreviations**

A definition of common terms related to EFPF, as well as a list of abbreviations can be found at <https://www.efpf.org/glossary>

## **0.9 External Annexes and Supporting Documents**

Annexes and Supporting Documents:

- None

## **0.10 Reading Notes**

- None

# 1 Matchmaking

## 1.1 Introduction

In the modern manufacturing era, supply chains are increasingly becoming multi-enterprise and global in nature. Agility, shared data and business collaboration are key factors for multi-enterprise supply chain success. To build agile multi-enterprise supply chains, companies first need to have access to a large supply base and secondly need an efficient mechanism for cost-effective and rapid identification, evaluation, and selection of suppliers and products & services provisioned by them. Matchmaking mechanisms for connecting buyers and sellers of manufacturing services based on different criteria are a powerful tool towards building global multi-enterprise supply chains. These mechanisms can be automated to make the overall process efficient and robust. A prerequisite for automated matchmaking is a formal representation of supply and demand data. Based on a common interoperable data model across integrated platforms of manufacturing and logistics suppliers and service providers, effective matchmaking mechanisms can be developed connecting buyers and sellers across heterogeneous manufacturing platforms.

In EFPF, several key manufacturing and smart factory tool platforms interlinked as a federation of digital manufacturing platforms. Namely, they are NIMBLE, COMPOSITION, DIGICOR (represented by SMECluster) and vf-OS. In EFPF, these platforms offer different types of manufacturing and smart factory solutions. With an effective matchmaking strategy these platforms can offer their products and services to a wider client audience through a unified EFPF portal with value added features.

The goal of matchmaking in EFPF is to facilitate EFPF users to find the best suited suppliers and enable them to transact with them efficiently and effectively. This is achieved through 4 layers of matchmaking in EFPF platform;

1. Federated search of participants (suppliers/service providers) & their value-units (products/services)
2. Platform recommendations of suppliers/service providers & products/services
3. Navigate users to perform negotiations and transactions with selected suppliers and service providers from different base platforms
4. Enable users to find the best supplier to fulfil a request for a service or product in a fully automated way (via automated agents)

In the following sections, these different layers of matchmaking will be discussed in detail.

## 1.2 Federated Search

This is the first level of matchmaking that is implemented in EFPF platform. A prerequisite to achieve a federated search is a common interoperable ontology for cross-platform search. The platforms need to be able to exchange data and facilitate effective information retrieval across the base platforms conforming to such an interoperable data model. Once a common interoperable ontology is defined, a dataflow mechanism should be implemented to ingest base platform data from heterogeneous sources to a common index which will be used as a federated search index across the EFPF platform.

In the following sections, the problems we address in federated search and possible techniques and architectures to solve the problems in federated search are explored in detail.

### 1.2.1 Federated Search Problems

Federated Search enables the simultaneous search of multiple sources, including document repositories, databases, remote repositories and external web sites. To enable federated features for websites to be searched by the user, e.g. for searching Twitter, Google News, etc., special search connectors need to be implemented and configured for each website (Orchilles, 2010). For example, MacOS Spotlight uses selection-based search and creates an index of all items and files on the system.

One of the biggest issues with the federated search relates to resource accessibility, thus requiring one large index to be created from those multiple sources that constitute federation (Melton and Buxton, 2006). Federated search allows for each source to be indexed locally and searched across many sources. Another issue of federated search is about the relevance of results that are obtained from a variety of sources. Here, the relevance of results needs to be synchronized and comparable across sources, in order for results to be merged in a meaningful way. In practice, even the results from the same source are not comparable when different search engines are used to retrieve these sources. Other anticipated problems are about content versioning in repositories, as well as adding federated search capabilities across some but not all resources that causes the incompleteness of the expected search results.

### 1.2.2 State of the art

Apart from Windows Search and Federated Search as described in (Orchilles, 2010), the authors in (Fei, 2009) differentiate between “federated search” and “metasearch”. Metasearch engines crawl open websites (Fryer, 2004) or return results of all kinds, such as apps, webpages, contacts, and documents that are drawn from different sources (as in MacOS Spotlight), while federated search systems focus on subscribed databases that are processed through an indexing mechanism with the aim to enable structured, in-depth, content-oriented retrieval (Tang, Hsieh-Yee and Zhang, 2007).

A number of attempts to implement federated search are made from the 1990s onwards, e.g. MetaLib and SFX at Boston College (Gerrity, Lyman and Tallent, 2002), MetaLib and SFX with Ex Libris at the Five Colleges Libraries in Massachusetts (Mestre et al, 2007), Georgia Library Learning Online (GALILEO) with its hybrid approach to federated search products (Fancher, 2007), and more. As for usability studies, many interviews shown that the users were unsatisfied with federated search performance, due to limitations in database availability, search speed, retrieval precision, and result comprehensiveness (Calhoun, 2005). Many users preferred simple interfaces and had little interest in advanced searching techniques, such as subject searching or combining indexes. Many users just left the search interface as the default setting (Tallent, 2004). In practice, federated search systems were and still are slow, their relevance ranking is limited and incomplete (Elguindi and Schmidt, 2012).

In recent years, several attempts to improve federated search were conducted. For example, in 2004, the University of Nevada at Reno experimented with the Google Search Appliance to be used as a federated search utility. This required partnership between Google, the library and a test vendor, but it ultimately faced technical and interoperability challenges (Taylor, 2006). In 2008, the authors in (Cooke and Donlan, 2008) compared

the results of “federated search engines” from Google Scholar, Microsoft’s Live Search Academic and Serials Solutions’ Central Search. By looking closer at sample searches of these three databases, the authors note that streamlined search interfaces may be equally useful, depending on the user’s preference and the information needs. As noted in (Mullen, 2010), Google Scholar is one of the heavily used databases at some institutions but is being left out of the federated search. Some other search engines trying to implement federated search were e.g. Summon by Serials Solutions, or dbWiz, developed by Canada’s Simon Fraser University Library. The authors in (Cooke and Donlan, 2008) emphasize that both commercial and free federated search engines permit users to indicate that they are affiliated with a particular information resource (library) so that they can retrieve full text from their licensed databases, as a prerequisite for any federated search product.

The information retrieval (IR) differentiate between the following types of search:

- **Ad-hoc search** is the “standard retrieval task in which the user specifies his information needs through a query which initiates a search (executed by the information system) for documents which are likely to be relevant to the user.” (Baeza-Yates and Ribeiro-Neto, 2010) Ad-hoc search does not assume any type for the input query and produce the most likely relevant documents as output without further filtering. Although it may look simple, it is quite a difficult retrieval task since there are not any means to understand the type of the input query.
- **People search** is a retrieval task in which the user specifies information needs in terms of people expertise, professional profiles, and other personal features through a natural language query for searching documents that are likely to speak about people relevant to the search parameters; for example, people search is performed by recruiters who look to hire relevant candidates.
- **Product search** is a retrieval task in which the user specifies search requirements in terms of product functionalities, price, and other product features through a natural language query for searching documents that are likely to speak about products relevant to the search criterion; for example, product search is performed by consumers who look to buy items by means of recommending systems.
- **Federated Learning (FL)** is a paradigm in machine learning where a model is learnt based on data that are privately owned by a set of clients. The server sends an initial model to the clients. Each client computes an update of the model based on private data and sends the update back to the server.
- **Recommendation systems** are utilized by the users to find products and by the producers to send recommendations to the users. One key source of evidence utilized to recommend products to users consists of reviews, which are naturally subject to bias and highly dependent on the credibility of reviews. Review-based recommendations constitute an interesting and challenging IR method since many data sources need to be taken into account simultaneously to generate the best results.

### 1.2.3 Federated Search Approaches

Federated search is a technique used to simultaneously search multiple data sources using just one query and one search interface. It can be used for a variety of applications, e.g. in case of multiple product databases used in addition to product catalogue, a federated search allows users to search from a single location and obtain results from all of the documentation and the product catalogue simultaneously (Algolia, 2019). Federated search examples can be found in many sectors, facilitating search of thousands of products, each sorted into different categories, thus maximizing the likelihood of a

successful sale, and facilitating search of numerous websites serving various purposes and stakeholders, e.g. investors, hiring, brand awareness, etc.

Majority of recent research on federated searching has focused on system performances and technical development, system implementation, and usability testing based on evaluation of search functionality, user interaction, interface customization, authentication, design, database communication protocol, vendor support, and system platform (Dorner and Curtis, 2004). The two fundamental components of each federated search product include an index and a search algorithm. An index is a reference to the data to be searched (parsed) by a search algorithm. These two components interact in different ways to achieve a federated search, e.g. using search-time merging, index-time merging and/or through a federated search interface (Algolia, 2019).

### 1.2.3.1 Search-time merging

This search runs separate search algorithms on each data source that is planned to be searched. It uses multiple indices and aggregates the returned search results into a final list, which is then presented to the user. Obtaining the search results can be slow, if the central search engine needs to wait until all of the local search engines have responded. Another issue is directly related to the interoperability and the relevance of the search results to be aggregated in a meaningful way, e.g. due to different formats of data. A potential cause of performance issues in search-time merging relates to a document-level security.

The advantage of this search method is easy to implement, as it does not require additional indexing of content.

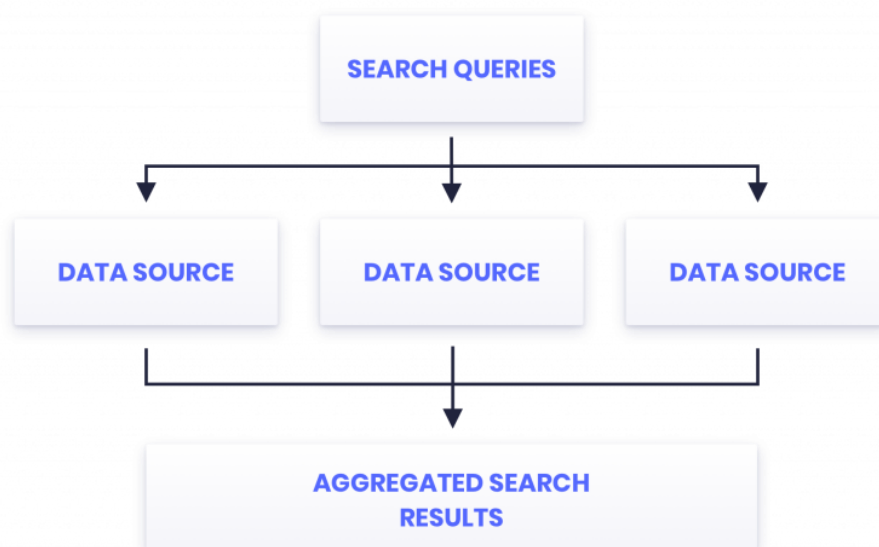

Figure 1. Search-time merging (source: (Algolia, 2019))

### 1.2.3.2 Index-time merging

This search requires building a central index of all of the data that needs to be included in the search results, and then searching that index to perform a federated search. It requires one search engine and one index, and is therefore faster than search-time merging (no need to wait on local search tools to respond to a query). At the same time, designing, setting up and maintaining such search methods are more complicated and require solving

interoperability challenges, e.g. how to aggregate data from multiple sources and formats into a single index. Once all data is fed into a single index, index-time merging requires a relevance strategy for all different types of content to be decided, which is not always possible to solve.

The advantage of this search method is that a central index enables sophisticated query enhancement and relevancy algorithms to be applied, which improves the search results.

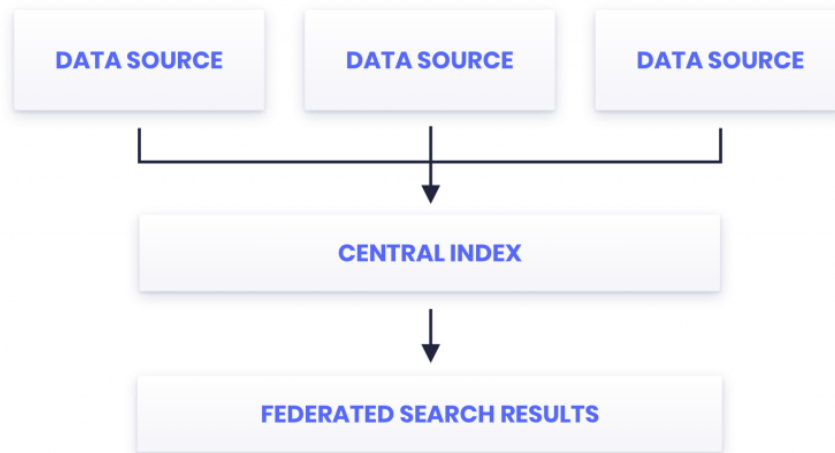

Figure 2. Index-time merging (source: (Algolia, 2019))

### 1.2.3.3 Federated search interface

This search is an extension of the search-time merging method. It requires a robust search solution that can index different types of content in different indices and create the unified federated search interface. It allows for tuning the relevance for each type of content independently.

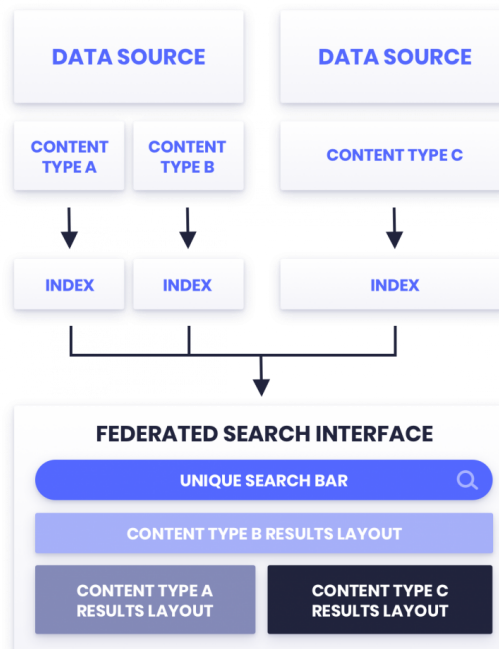

Figure 3. Federated search interface (source: (Algolia, 2019))



## 1.3 Design of Federated Search and Recommendation Mechanisms in EFPF

The EFPF platform is a digital platform ecosystem that encompasses four digital manufacturing platforms: NIMBLE, COMPOSITION, DIGICOR and vf-OS, including some of their tools and services. In addition to these four platforms, EFPF is designed to be extended towards external platforms in the future. Such a design approach requires that interoperability and federation challenges need to be resolved with a high priority, enabling tools and services from various platforms to be used and their results merged in a beneficial manner. For example, enabling matchmaking and agile network creation mechanisms in EFPF requires federated search to be put in place, in the first instance.

Federated search mechanisms in EFPF are about searching for partners and/ or for products and services. The EFPF user is able to search for partners across the base platforms, based on different criteria, e.g. capabilities of partners, their geographic locations and acquired feedback and online rankings. The EFPF user is also able to search for products and services based on product/ service-related criteria. The search criteria and the results are collected in order to support the recommendation process for both partners, and for products/ services based on different techniques of information pattern matching. These techniques include information retrieval and similarity matching techniques, which are both based on Machine Learning (ML) and data analysis. After the most suitable partners and products/services are identified by recommendation algorithms, the users evaluate the results based on several selected indicators, e.g. cost, reliability, quality, etc. Finally, in the third step that is about matchmaking, the user decides how to proceed with it and initiates a suitable business transaction.

### 1.3.1 Federated Search

A federated search in EFPF enables a search functionality over multiple sources using one query. The architecture for federated search is derived considering the existing base platforms' architectures and features, available data sources and other technical requirements related to the design of a recommendation engine. In EFPF, we follow the index-time merge architecture to implement a federated search approach. The main reason to select index-time merge architecture over search-time merge and hybrid architectures is due to non-availability of search indices in the majority of the base platforms. Only NIMBLE currently has a search index to provide text-based search functionality.

The index-time merge search requires content from base platforms to be acquired into a central index at the EFPF platform, in order to enable platform level search for products/services and partners/companies across the four base platforms. The index-time merge search is also used to implement traditional enterprise search systems, in which information can be retrieved across heterogeneous data sources in an enterprise. Figure 4 depicts the index-time merge architecture for federated search in EFPF.

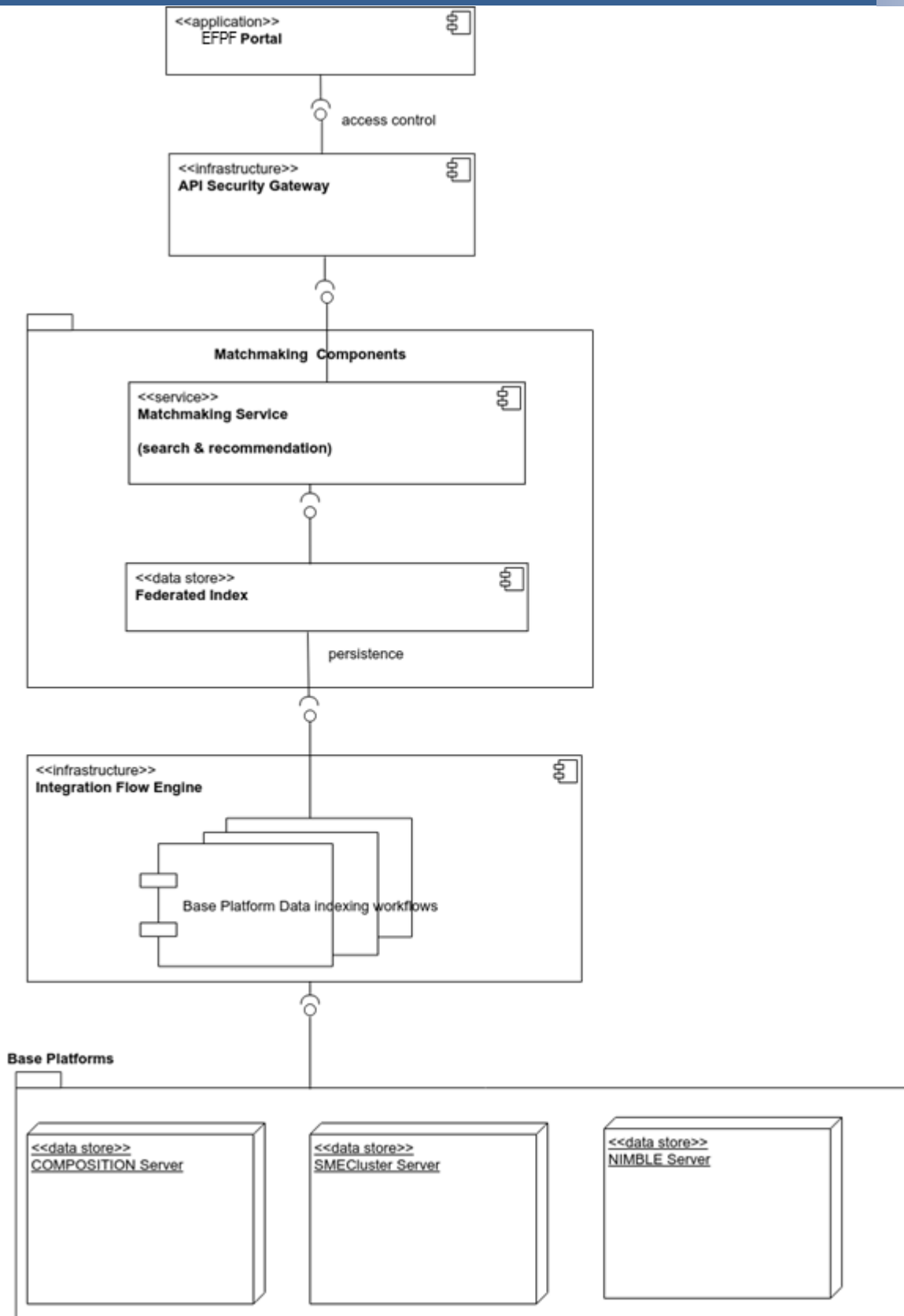

Figure 4. The Index-Time Merge Federated Search Architecture



The major advantages of the index-time merge architecture, as shown in Figure 4, are as follows:

- Through acquiring all data into a central index, sophisticated query enhancement and relevancy algorithms can be applied, providing the user with excellent search results.
- The selected search architectural approach allows for flexibility in the implementation of the recommendation and matchmaking engine.
- The indexed data and ML algorithms can be used to provide product/services/partners recommendation.

The following disadvantages of the index-time merge architecture are summarised below:

- Acquiring the content from the various repositories and data sources of the base platforms requires considerable efforts; for example, it needs to be done using scheduled read-only processes that would need to be designed and implemented at the data integration layer. This also requires a decision about the frequency of the data ingestion into a central index. Data ingestion frequency needs to be configured hourly, daily or weekly, depending on the data velocity of the base platforms.
- For different types of data sources, additional data connectors need to be implemented to enable the data integration.

### 1.3.2 EFPF Manufacturing Ontology

The type of data collected from the base platforms include data of companies, service providers and products & services offered by them. The base platforms have different data schemas to define these entities. In order to capture different attributes of the entities (companies & products/services) these base platform data schemas need to be consolidated into a common schema/ontology.

To enable an effective federated search in EFPF, we designed a common ontology called EFPF Manufacturing Ontology (EFONT) that includes the following concepts (see Figure 6):

- A Class/ Category of a product/ service/ partner's capability has 0 or more properties;
- A Property describes the product/service class in detail, e.g. length, height, certificates;
- An Item is an instance of a Class/ Category. Each Class/ Category has 1 or more item instances representing the actual product/service or partner's capability that will be manufactured/ provided by a party/ company;
- A Party has attributes such as a legal-name, keywords and activity sector that extend a variety of attributes for matchmaking processes.

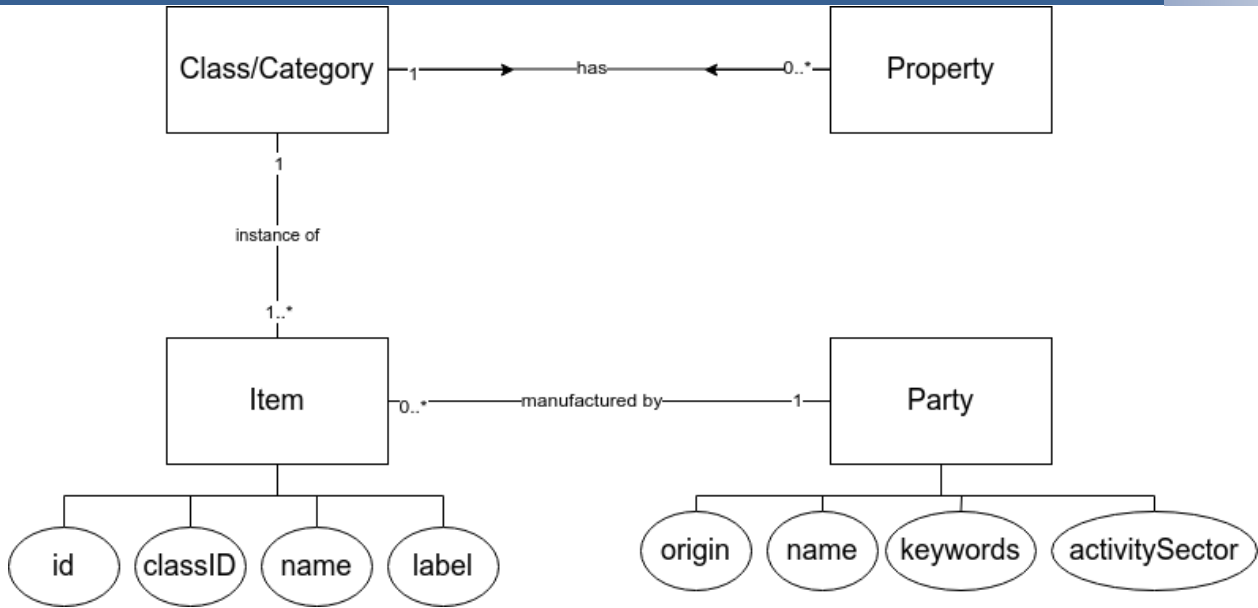

Figure 5. A High-Level View of the EFPF Manufacturing Ontology

The concepts and their attributes defined above are inspired by the Universal Business Language (UBL) specifications on Supplier PartyType (SupplierPartyType, 2013) and CatalogueType (CatalogueType, 2013). We extended the above ontology with more attributes which will be useful for matchmaking transactions and the extended version of the EFONT is depicted below in Figure 7. The additional relations/attributes were added mainly to the Item and Party concepts by analysing the different schemas used across the base platforms. Some of the main attributes of the concepts are as below.

- Party: Legal name, brand name, business type, origin, address, website, projects, trust score
- Item: Label, manufacturerID, price, packageUnit, packageAmount, totalCapacity, deliveryTime, certificateType

The extended full EFONT ontology is depicted below in Figure 6.

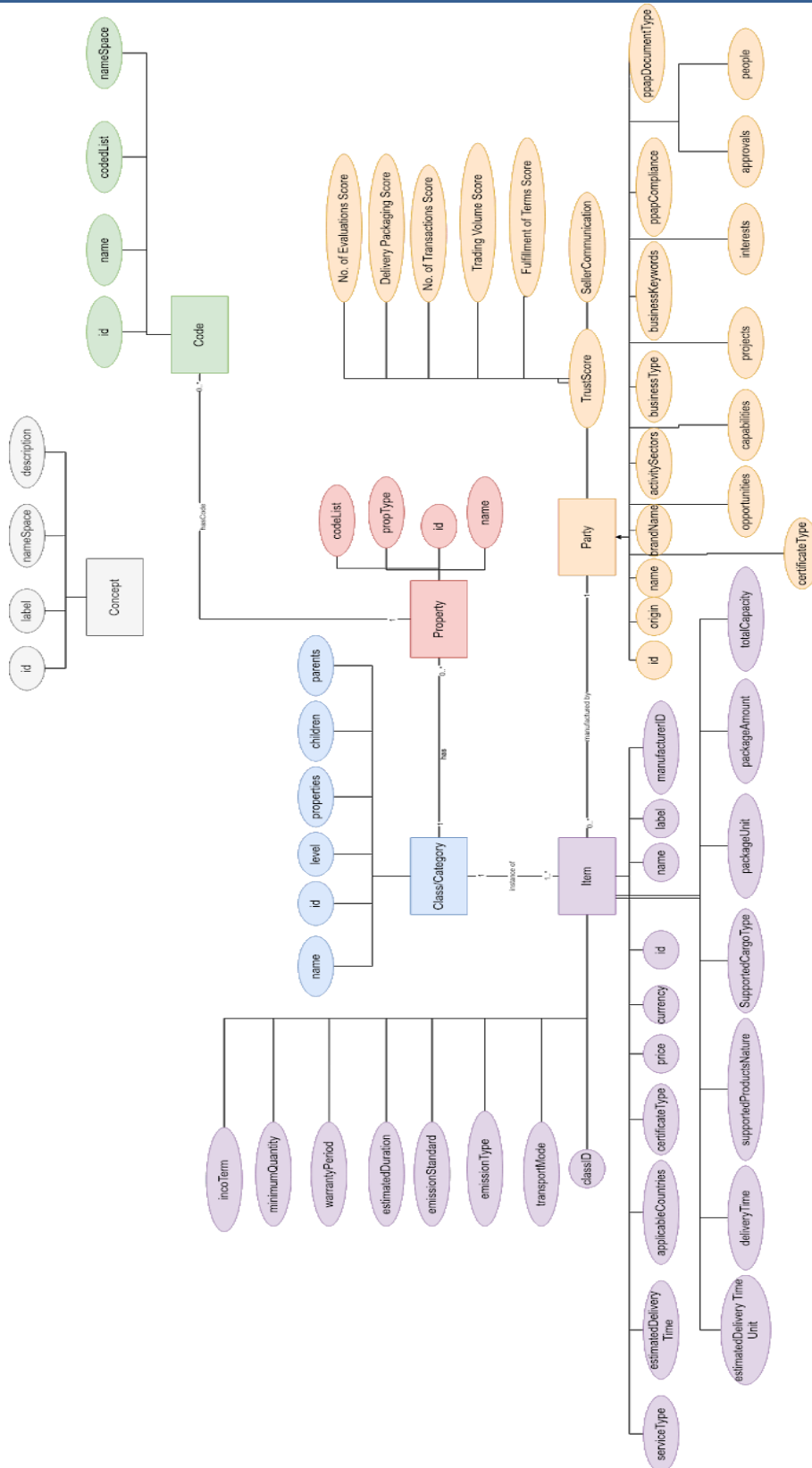

Figure 6. Extended EFPF Manufacturing Ontology

The data from different base platforms are retrieved and indexed into above common EFONT ontology using a data flow process implemented in EFPF Integration Flow Engine/ Data Spine. The next section describes the details about the matchmaking data flows and the implementation details of the indexing workflows of base platform data.

### 1.3.3 EFPF Matchmaking Data Flows

The main data flows in matchmaking components can be depicted as below.

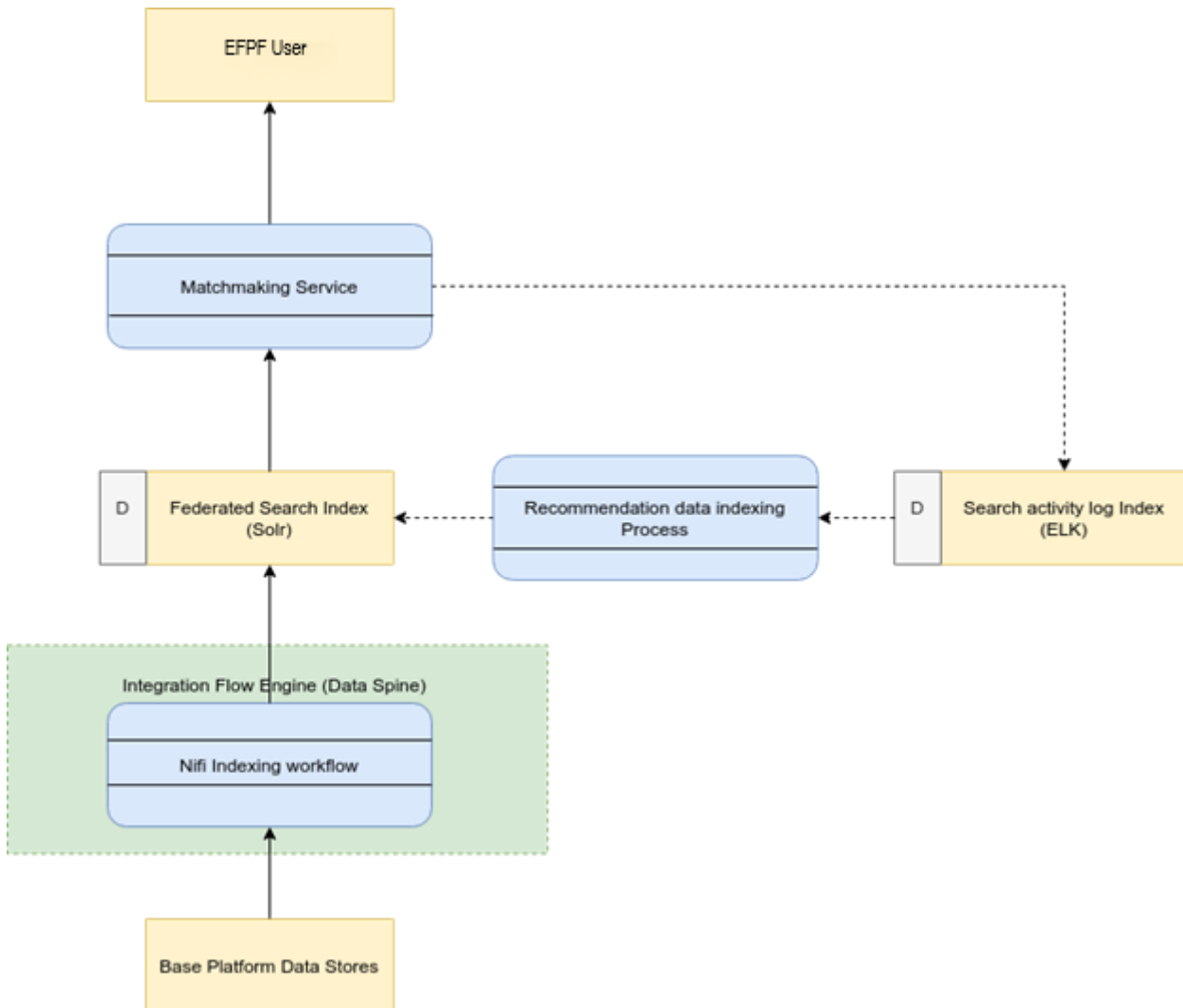

Figure 7. Data flow in EFPF Matchmaking Components

The main data flow is the one from base platform data stores (most base platforms expose their data stores via an API) to the federated index in matchmaking via the indexing processes running on the integration flow engine (data spine). The data ingestion process is implemented as a set of Apache Nifi workflows. This data flow is triggered periodically to retrieve the latest data from the base platform. The schedule is configured in Nifi configurations in the processes.

For the implementation of the federated search-index as a data store, we use Apache Solr which is a scalable and fault tolerant search platform that provides distributed indexing, replication and load-balanced querying, automated failover and recovery, centralized configuration and more. The EFONT ontology content needs to be indexed by the Apache Solr, in order to ensure that all required information about participants and value-units (domain knowledge) can be captured during the search process.

In the indexing workflow a data transformation occurs between the incoming data model to the federated data model. The federated data model is discussed in detail under EFPF Manufacturing Ontology in the next section. The data transformation is implemented using

Nifi Jolt transformation processor. Jolt (Json Language for Transform) is an open-source JSON to JSON transformation library. It allows the developer to define rules of transformations as a JSON specification file. The Jolt transformation processor in Apache Nifi processes the incoming data flow file and executes the transformation rules and converts the data flow file to the target schema in the Nifi workflow. Then a Solr output processor is configured as the final processor in each indexing workflow to index the data into the EFPF federated index.

Another dataflow happens at service level, from the federated index to the EFPF client via the search & recommendation service (matchmaking services). This dataflow is connected to the EFPF portal application as a REST API.

The search events (user's search queries and filtering queries) are received from the EFPF portal and logged in the EFPF data analytics framework. This analytics framework is implemented using Elasticsearch, LogStash, Kibana (ELK) stack. This data is utilized effectively in the network intelligence components in EFPF. Furthermore, this event data is utilized by the recommendation service in matchmaking in a feedback loop to provide personalized recommendations of companies and products/services to the EFPF users on the portal, based on past data on search queries.

Following section describes the details about the different indexing workflows of EFPF connected base platforms.

### 1.3.4 Indexing Workflows

The integration flow engine encompasses the ETL (data extraction, transformation and loading) workflows to ingest data to the federated index from the base platform data sources. Following sections describe the individual base platform data indexing workflows implemented thus far.

### 1.3.5 COMPOSITION Data Indexing Workflow

The COMPOSITION platform has exposed data about companies and products/services as RESTful APIs.

- COMPOSITION companies data API endpoint : [https://inter.composition-ecosystem.eu/matchmaker/COMPOSITION\\_RBMM\\_Restful\\_WS/RBMM/getMarketplaceCompanies](https://inter.composition-ecosystem.eu/matchmaker/COMPOSITION_RBMM_Restful_WS/RBMM/getMarketplaceCompanies)
- COMPOSITION services data API endpoint : [https://inter.composition-ecosystem.eu/matchmaker/COMPOSITION\\_RBMM\\_Restful\\_WS/RBMM/getMarketplaceServices](https://inter.composition-ecosystem.eu/matchmaker/COMPOSITION_RBMM_Restful_WS/RBMM/getMarketplaceServices)

These APIs are secured with basic authentication (username, password). The indexing workflow is configured with the basic authentication credentials to retrieve data.

The Jolt transformations of COMPOSITION indexing workflows are as below.

```
[
  {
    "operation": "shift",
    "spec": {
      "*": {
        "company brand name": "[&1].en_brandName",
        "company legal name": "[&1].legalName",
        "description": "[&1].description",
        "COMPOSITION system rating": "[&1].trustRating",
        "location": "[&1].en_origin",
        "business type": "[&1].businessType",
        "origin country": "[&1].en_origin",
        "logo": "[&1].logoId",
        "id": "[&1].id",
        "activity sector": "[&1].en_activitySectors",
        "trust-score": "[&1].trustRating",
        "website": "[&1].website"
      }
    }
  },
  {
    "operation": "default",
    "spec": {
      "*": {
        "basePlatform": "composition"
      }
    }
  }
]
```

Figure 8. COMPOSITION company data JOLT transformation

```
[
  {
    "operation": "shift",
    "spec": {
      "*": {
        "provided by": "[&1].manufacturerId",
        "service": "[&1].en_label",
        "description": "[&1].en_desc",
        "product": "[&1].en_label"
      }
    }
  },
  {
    "operation": "default",
    "spec": {
      "*": {
        "basePlatform": "composition" |
      }
    }
  }
]
```

Figure 9. COMPOSITION service data JOLT transformation

### 1.3.6 SMECluster Data Indexing Workflow

SMECluster (representing DIGICOR) platform also exposes data about companies and products/services as RESTful APIs. They have exposed multiple APIs with different levels of data granularity. Currently following APIs are connected in the matchmaking indexing workflows.

- SMECluster companies data API endpoint :  
<https://www.smecluster.com/api/DirectoryWebService/GetAllCompanies>
- SMECluster services data API endpoint :  
<https://www.smecluster.com/api/CatalogueUtilsWebService/GetAllProducts>

Following are the Jolt transformations of SMECluster data indexing workflows.

```
[
  {
    "operation": "shift",
    "spec": {
      "*": {
        "Name": "[&1].legalName",
        "Description": "[&1].en_description",
        "Logo": "[&1].logoId",
        "Website": "[&1].website",
        "CompanyID": "[&1].id"
      }
    }
  },
  {
    "operation": "default", |
    "spec": {
      "*": {
        "basePlatform": "smecluster"
      }
    }
  }
]
```

Figure 10. SMECluster company data JOLT transformation

```

[
  {
    "operation": "shift",
    "spec": {
      "*": {
        "Name": "[&1].en_label",
        "Description": "[&1].en_desc",
        "Price": "[&1].eUR_price",
        "ImageURL": "[&1].image",
        "URL": "[&1].id"
      }
    }
  },
  {
    "operation": "default",
    "spec": {
      "*": {
        "basePlatform": "smecluster",
        "manufacturerId": "SMECluster" ,
        "eUR_currency": "EUR"
      }
    }
  }
]

```

Figure 11. SMECluster product data JOLT transformation

### 1.3.7 NIMBLE Data Indexing Workflow

The NIMBLE base platform already has a data indexing workflow to its base search index (Apache Solr). NIMBLE can be configured to index the data to multiple indexes. Instead of defining a periodic data indexing workflow in EFPF integration flow engine, the NIMBLE base platform instance is configured to index its company and products data upon creation, to the federated index in real time.

### 1.3.8 Recommendation Service

The second step of the matchmaking process is to enable effective recommendation services for both partners system and products/ services. Figure 12 gives a high-level design view of the recommendation system in EFPF.



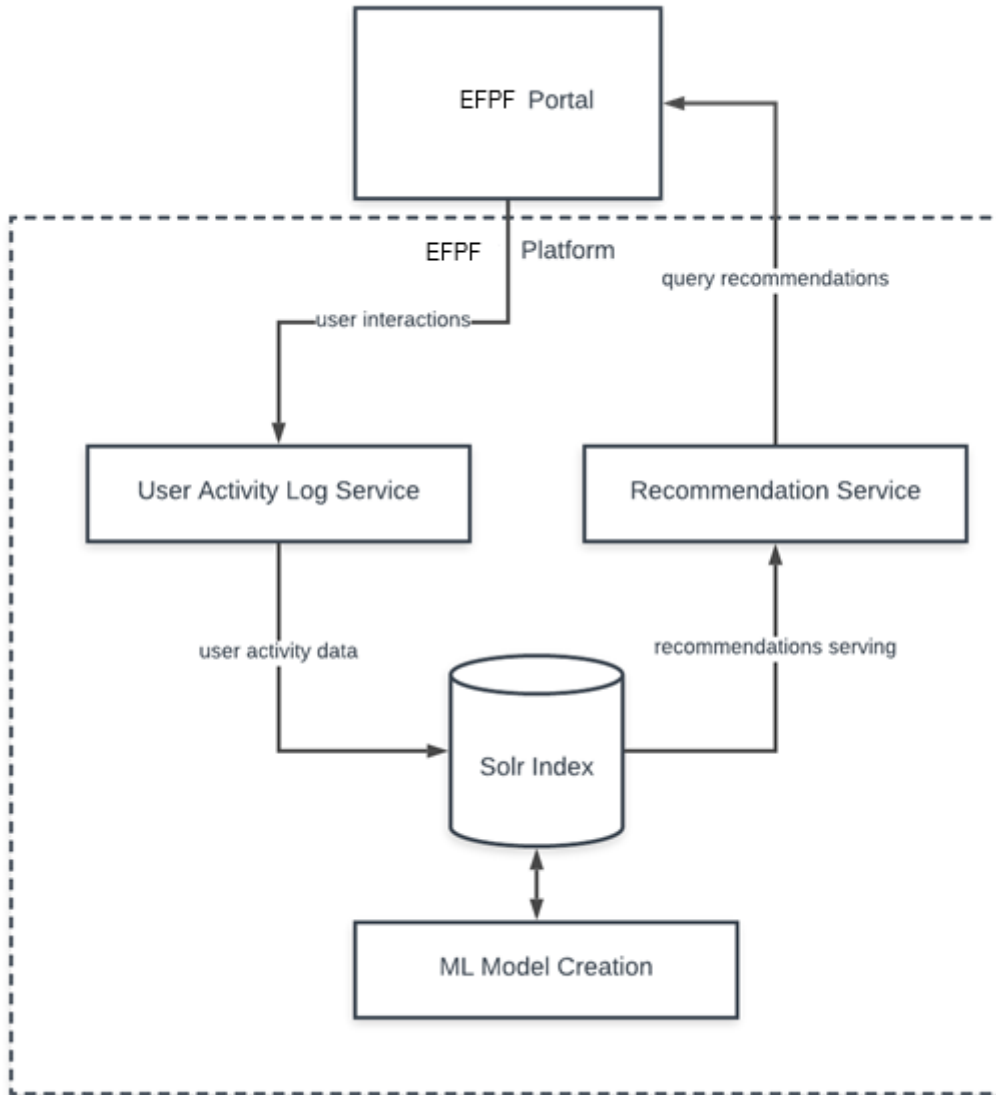

Figure 12. A High-Level Design of the EFPF Recommendation System

Currently the user activity data concerning federated search events are logged in the ELK stack. Following are few metadata captured in a search event in EFPF portal.

- Search type: product or company search
- Search query: the main query and associated faceted queries
- Search response: the associated search response for the executed query and the facets
- Date & time of the query
- The search results the user clicked on and proceeded with purchasing

These captured data will be fed into a Machine Learning model to predict the relevance of different products/services and service providers to each user. This model will be iteratively trained in a training pipeline and connected to the ranking model of the search framework to give automatic search recommendations to the EFPF users.

The implementation of the recommendation system will be realized from Month 18 – Month 24 of the project. Currently this service is in the design phase.

### 1.3.9 Discussion of the Current Results

The matchmaking process in EFPF includes both federated search and recommendation services, which are executed through the EFPF Portal and its user interfaces (UIs) for entering search criteria. These services enable EFPF users to find and select most suitable service providers and their products & services via information retrieval techniques.

The search user interaction data are stored using the User Activity Log Service, which listens to all user interaction events generated from the EFPF Portal, e.g. item views, purchased items, etc. In addition to maintaining the data about partners, products and services, the matchmaking process in EFPF also stores all the user interactions data through Solr Index. This data will be used for ML model creation, based on an ML library (Apache Mahout) that is used to create item-similarity and user-similarity-based search recommendations to the user. The recommendation service includes the ML models served via a REST API on top of the Solr search API and is based on similarity matching.

Finally, the outcomes of the matchmaking are presented to the users through an intuitive UI that is integrated in the EFPF Portal, as illustrated in Figure 13.

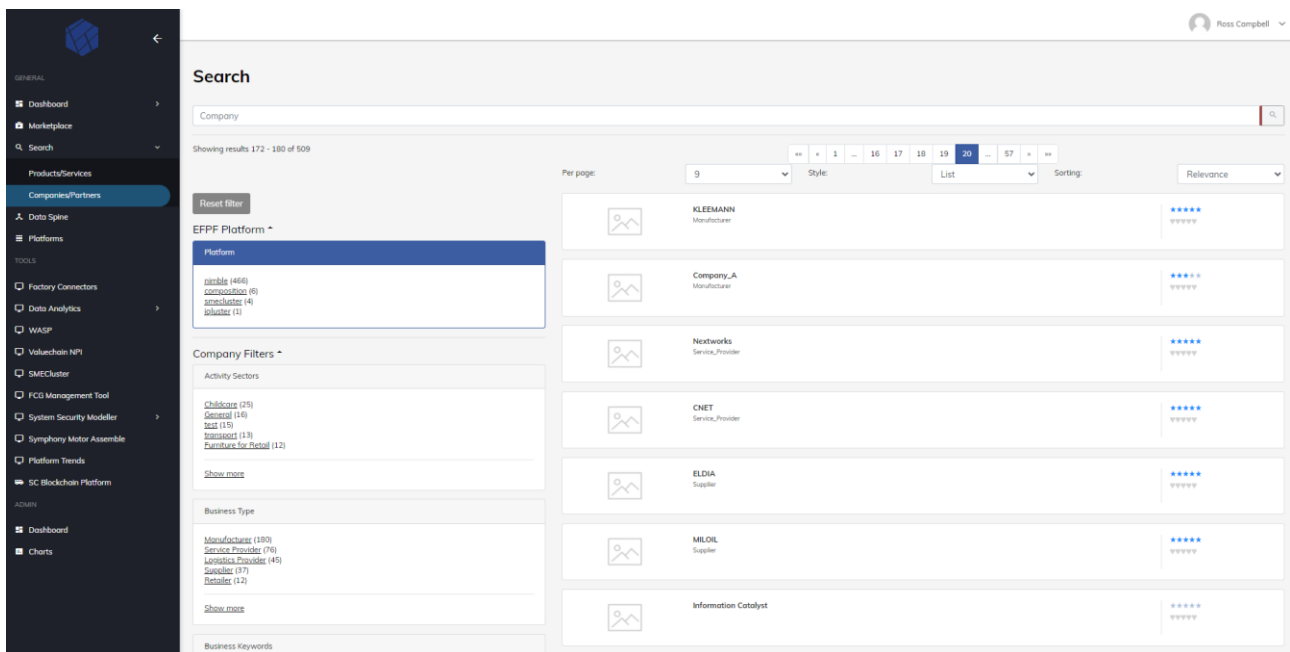

Figure 13. EFPF Federated Search UI

The user is given search term suggestions when he enters a search term. This makes user's search queries efficient and effective. These suggestions can be ranked according to many criteria such as similarity-based ranking, most searched terms based ranking and personalized search terms-based ranking, etc. Currently this is configured to similarity score-based ranking (most similar text suggestions to the entered search term are ranked higher).

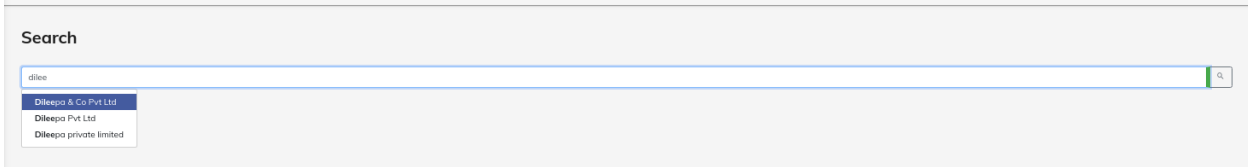

Figure 14. Search Term Suggestions

Once the user gets a set of search results, he can use the granular level filters given to drill down the results based on a range of facets based on the EFONT ontology. For an example, once a user gets a set of results based on the search query entered, he can further drill down the results based on facets such as platform, activity sector, business type, origin location and trust scores of the service provider as depicted in Figure 15.

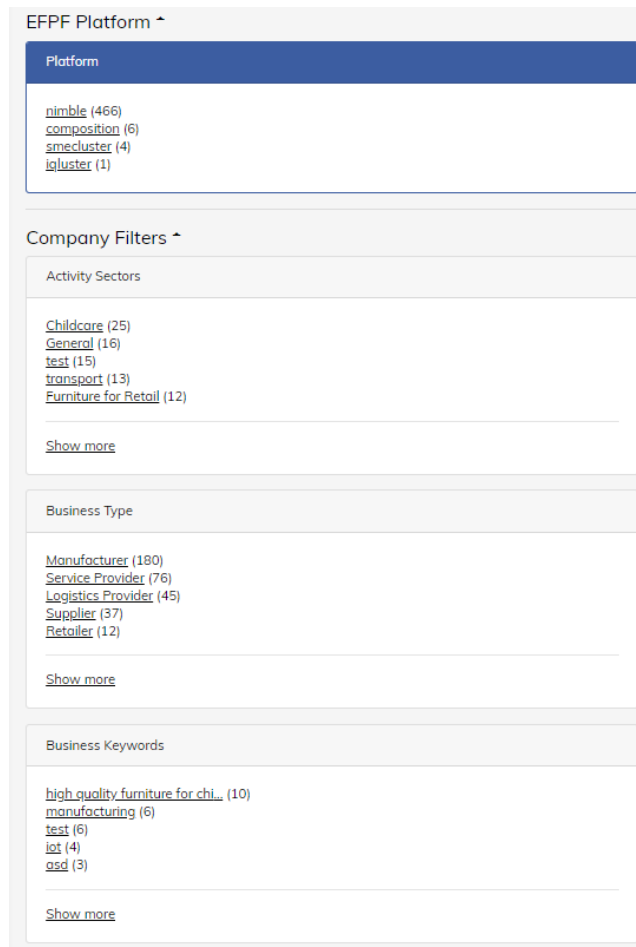

Figure 15. Filter Options

Furthermore, the user can click on the interested product or service provider in the results list and view further details and options to execute a business transaction or business negotiation with the service provider. The user is redirected to the base platforms company and product pages via EFPF user federation to continue his transactions seamlessly within the connected platform ecosystem in EFPF. Following are examples of a service provider and product details pages in base platforms integrated into the federated search in EFPF.



Figure 16. Service Provider Details Page

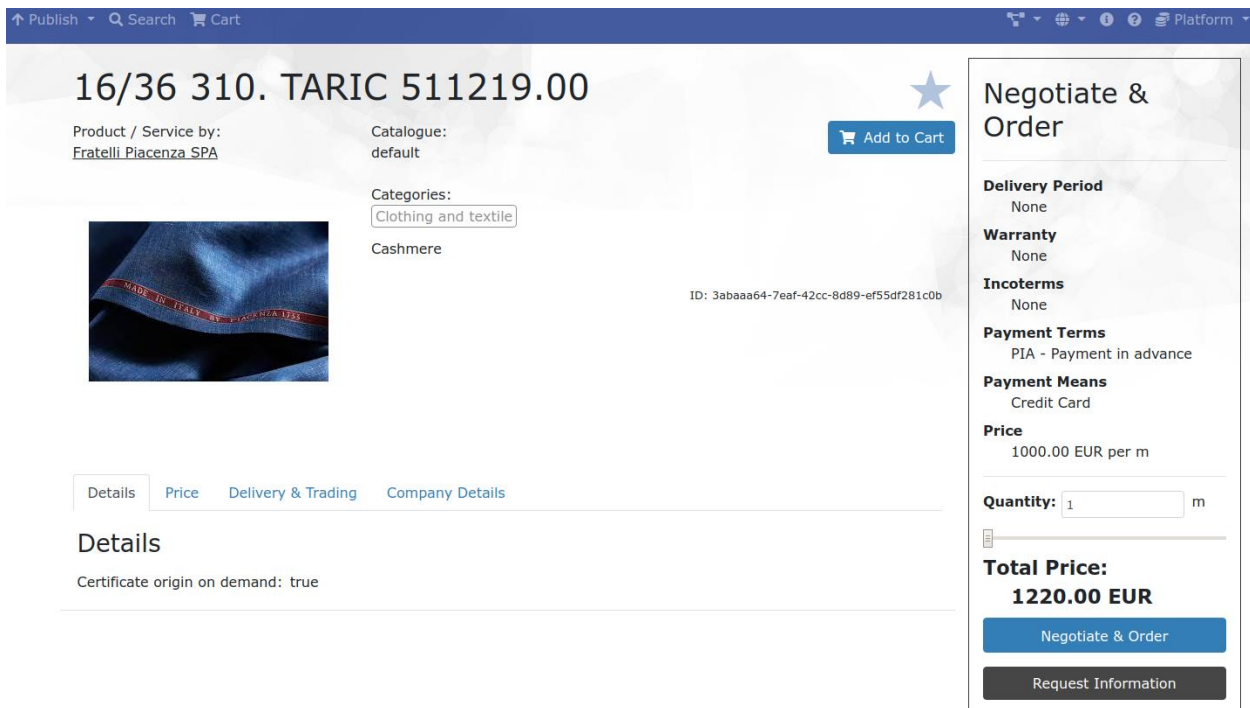

Figure 17. Product Details Page

## 1.4 Matchmaking Services for Automated Online Bidding

This service is an extension of EFPF matchmaking capabilities. Federated search and recommendation service architecture provides the EFPF user with flexibility to find and select the best suppliers and products/services via information retrieval techniques. This service provides an automated matchmaking mechanism for information requests from buyers to suppliers, to execute negotiations and business transactions automatically via configured agents.

### 1.4.1 Problem Statement

The Automated Online Bidding differs from the aforementioned search and recommendation systems. It is a matchmaking application which achieves automated negotiations and business transactions between interested stakeholders. The matchmaker's goal is to find the best possible supplier to fulfil a request for a service or product in a fully automated way. Different decision criteria for supplier selection, according to several qualitative and quantitative factors, are considered by the matchmaker. It also evaluates the available offers from the providers in order to suggest the best one to the supplier.

This specific tool aims to address the challenges and realize the Circular Economy Scenario of EFPF. KLEEMANN (KLE), ELDIA and MILOIL are the three participants of the scenario, focusing on Closed-Loop Supply Chains. The scenario starts with KLE granting the potential to a stakeholder business to collect and manage waste material on a marketplace, like wood waste or scrap metal. Then, ELDIA and other interested companies attend the process of online bidding in order to acquire the business contract. The winning bidder can use the marketplace again to sell the waste to bio-energy companies such as MILOIL. The recycled material is offered back to KLE and other manufacturers through the marketplace for reuse, completing the business circle. Figure 18 is a comprehensive illustration of the circular economy scenario.



Figure 18. Circular Economy Scenario of EFPF

The Matchmaker’s functionalities which will be described in detail below, are fully exploited by the circular economy scenario. The Agent Level Matchmaking is extensively used for discovering services, products and capabilities as well as available agents and stakeholders, whereas the Offer Level Matchmaking module is operating for the bidding process and the automatic negotiations among the scenario participants.

### 1.4.2 State-of-the-art

There are several techniques regarding semantic representation and matchmaking and some of them are presented hereby. An agent-based system which performs different level information management activities is InfoSleuth (Nodine, 2000). InfoSleuth offers a set of Broker agents which provide syntactic and semantic matchmaking between services' providers and requesters by using a specific "InfoSleuth ontology". IMPACT (Interactive Maryland Platform for Agents Collaborating Together) (Arisha, 1998) is an international research project, related to software implementation that facilitates the creation, deployment, interaction, and collaborative aspects of software agents in a heterogeneous, distributed environment. Furthermore, Digital Manufacturing Market (Ameri (AMeri), 2012)

is a multi-agent web-based framework that contains a manufacturing services ontology and a matchmaking mechanism which matches a consumer's requirements with suppliers' manufacturing capabilities. Lastly, FITMAN-SeMa (Metadata and Ontologies Semantic Matching SE) (FITMAN-SeMa, 2018) is a component of FIWARE (FIWARE, 2018) for 'smart industry' and provides storing and retrieving functionalities for ontologies and triplets. By using various algorithms FITMAN-SeMa performs effective semantic matching.

The matchmaking over bidding definitely includes the evaluation of given offers and the best offer selection. An interesting approach related to offer evaluation in an automatic way is the decision support tool presented in (Idrees, 2015). This study mentions the evaluation steps taken in order to make a decision towards the best offer. Nevertheless, weighted criteria assessment can also be implemented as a part of matchmaking and enhance even the previous method, so a small literature review is presented at this point. Multiple decision-making problems enclose the determination of the optimal alternative from several potential candidates in a decision, depending on several criteria or attributes that may be concrete or vague. The most widely used method is the Weighted Sum Model (WSM) (Fishburn, 1967). This method requires a dataset expressed in the same unit for each alternative, thus it is an utmost convenient method for single-dimensional problems. The analytic hierarchy process (AHP), is another popular method (Saaty, 1994). AHP is similar to WSM, thus it can be applied in both single and multi-dimensional problems, since it uses relative values for each alternative and not the actual ones which add up to one. A revised AHP method was introduced later on (Belton and Gear, 1981) with some effective modifications. The extension of the method is that instead of calculating relative values of the alternatives sum up to one, each relative value is divided by the maximum value of the relative values.

### 1.4.3 Design of the Semantic Matchmaker

The matchmaker component provides an explicit match of requesters and suppliers which participate in an ecosystem and enables automated negotiations. It is a rule-based matchmaking engine enhanced with multi-criteria algorithms for offers' evaluation. It supports semantic matching in terms of services, products and business entities' capabilities at the EFPF platform and is used in cross domain scenarios in order to enable a real time bidding process.

The actual actors of the matchmaking component are the Agents. They instantiate the supply-chain formation strategy of industry stakeholders and are in charge of triggering the start of the automated negotiations. The Requester and the Supplier are the two types of stakeholders/agents which request the matchmaker services in order to:

- Request the list of the suitable agents for a certain negotiation, e.g. the agents offering a certain service on the marketplace
- Evaluate the offers that have been received during a negotiation

The matchmaking application contains a comprehensive representation of the marketplace ecosystem encompassed by the system's core Ontology coming from the COMPOSITION project's Collaborative Manufacturing Services Ontology and its thoroughly defined data models. Semantic rules and queries are designed and executed in order to achieve optimal suggestions and matching between Requesters and Suppliers. Stakeholders and Agents are external participants of the matchmaking application, but as it is crucial, they have to reflect the classes, functions and attributes defined in the common ontology, so as to enable interoperable behaviour and matching. Matchmaker is a RESTful application,



using open source components combined with custom-made components towards an automated matchmaking procedure. Its integrated and modular architecture is described in detail below. The technical details of the design and implementation of the Semantic Matchmaker will be analysed in this report. The corresponding interfaces are presented in the dedicated report of D5.13 - EFPF Interfacing, Evolution and Extension.

The Semantic Matchmaker is built upon Apache Jena framework (Apache Jena, 2018), a free open source Java framework suited for Semantic Web and Linked Data applications. Jena provides a programmatic environment for RDF, RDFS and OWL, SPARQL, GRDDL, and includes a rule-based inference engine. The Semantic Matchmaker application has adopted the architecture depicted in Figure 19, including:

- The Ontology Store (RDF triple store), initialized by the System's Service Ontology.
- The Ontology Query Engine inside the corresponding Ontology API which enables the manipulation of the Ontology Store by the Marketplace Agents and Stakeholders.
- The Matchmaker API, which exchanges information through the Ontology Model with the Ontology Store. Two matchmaking levels are developed, the Agent and Offer Level matchmaking. Both use the Semantic Rules Module for the matching, while the latter matchmaking level implements the Weight Assessment module.
- The Rest API, on the top of all APIs, which enables the requests of Agents and Stakeholders in the Semantic Framework's different components.

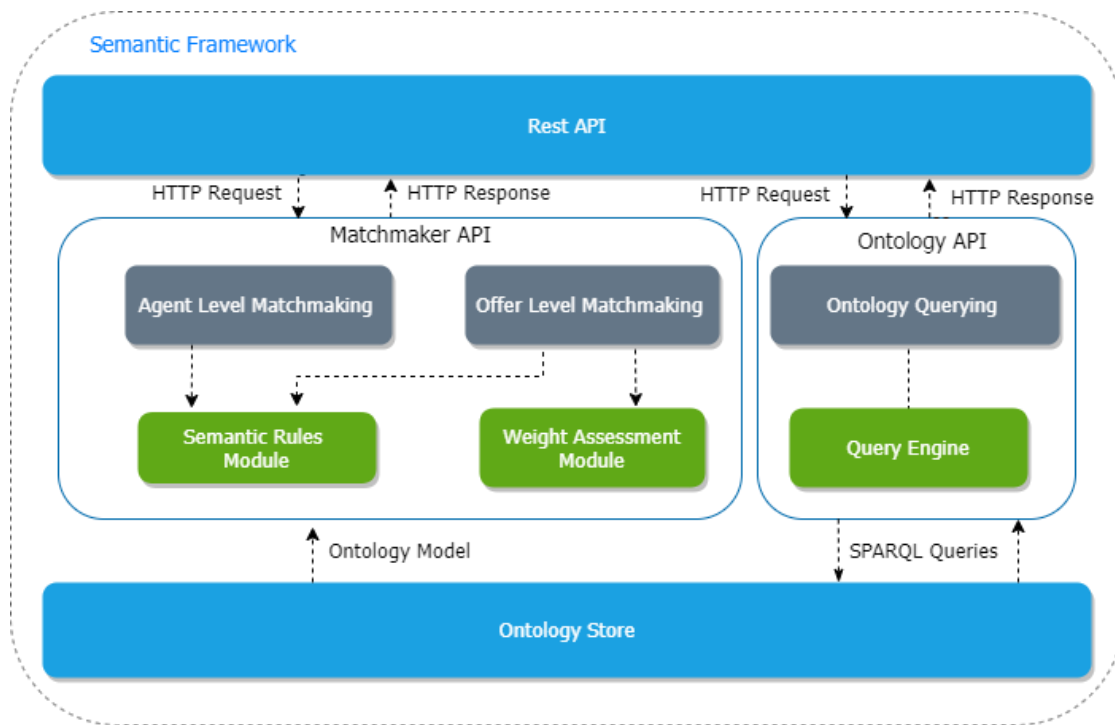

Figure 19. Semantic Framework's Architecture

The Semantic Matchmaker's core functionality is to receive Agents and Stakeholders' requests via the Semantic Matchmaker API and carry them out through the Semantic Rules and Weight Assessment Modules. In order to start the matchmaking process and execute an external request the Matchmaker follows some specific steps.

The Semantic Matchmaker receives the requests from the Agent or Stakeholder (requests are based on REST and HTTP). At once, the Matchmaker accesses the available services

from the Ontology Store. An Ontology Model is then created in the memory. The Semantic Matchmaker transforms the request from its initial format (JSON format) to the Ontology compatible format and creates the necessary instances. Then, the Semantic Matchmaker collects the proper Jena rules list, depending on the type of the incoming request. A reasoner is created by calling an instance of a reasoner class or by retrieving from the reasoner registry which contains instances indexed by URI assigned to the reasoner. The rules' list is set after the reasoner instance is created. This way, the reasoner obtains the set of rules that should be executed. An inference model is created after applying the reasoner to data. The Semantic Matchmaker, then, accesses the information stored in the inference model.

After the execution of the request either by implementing the Agent Level or the Offer Level Matching, the output is constructed by the following way. The module transforms the inferred information to agents' request format. Finally, the output is returned as a response via Semantic Matchmaker API (REST and HTTP) to the Agent in a format compatible to the agents' request format. At this level of matching the semantic rules are focused on service level. For an agent who requests a service in the Agent Ecosystem, the Matchmaker will provide the agents which offer this service.

### 1.4.3.1 Agent Level Matchmaking

The Agent Level Matchmaking focuses on matching agents and stakeholders which are possible customers and suppliers. The Matchmaker applies the semantic rules constructed with ontology classes of Business Entity, Service, Operations, Goods and the properties between them. The execution of the rules achieves to infer knowledge and trigger negotiations among the Marketplace stakeholders. A list of possible suppliers or customers is returned to the requester agent.

Figure 20 is a diagram illustrating the Agent Level Matchmaking procedure. The Agent Request is a JSON request including the requester's personal information and the services or products that the requester is seeking. The Semantic Rule engine retrieves the information from the ecosystem's Ontology and the Semantic Matchmaker responds with a set of agents which provide the requested product, service or capability.

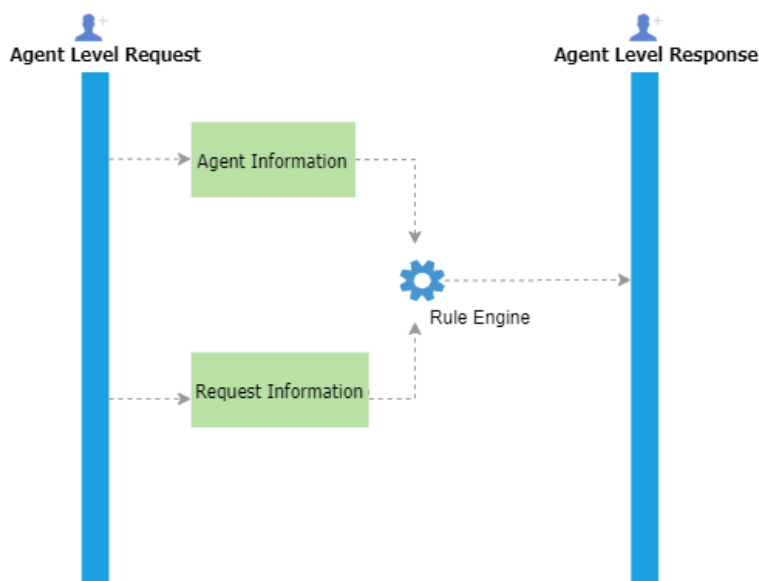



Figure 20. Agent Level Matchmaking process

The semantic matchmaker has the ability to match these requests based on the services and products but mostly on common operations and goods that exist in the ecosystem's Ontology. Every business entity uses its own terms to describe one of its offered services and products. However, every one of these vendor specific terms will be mapped with a common operation. This way, on the one hand every business entity participates in the Marketplace and advertises its services and products with its own terms, whereas, the Matchmaker matches similar concepts in order to set the Marketplace capable to relate offers and requests among stakeholders or to find possible solutions for some Marketplace participants.

Moreover, further rules can be added in order to give a matchmaking result based also on some criteria by the requesters as a kind of filtering. Additional criteria by the requester agent can improve the Matchmaker's result. After the initial matching based on the provided services the Matchmaker is able to apply more rules in order to exclude some suppliers from its final output. The rules that will be applied are related to quantitative criteria of the services.

#### 1.4.3.2 Offer Level Matchmaking

The Offer Level Matching regards the process of offers' evaluation achieving online bidding for fully automated negotiations. Starting with an agent or stakeholder which provides a set of offers that this agent or stakeholder had received from supplier agents, the Matchmaker is responsible for the bidding procedure in order to return the most convenient offer. The Offer Level Matchmaking follows a multi-criteria decision-making method combining the semantic rules inference with the enhancement of a weighted criteria assessment algorithm.

Figure 21 is a high-level illustration of the offer evaluation process, highlighting the involvement of several criteria extracted from the agent's input. The properties of the Offer Level Request (JSON format) are annotated in order to form the weighted criteria. The criteria are evaluated and extract the best evaluation score and return the best suggested offer.

The criteria are formed by extracting the following information from the Offer Level Request body:

- **Agent Terms:** The Service, Transportation and Insurance Price given by the offers request, sum up to an overall price. Also, the Delivery time and Payment terms (credit).
- **Fulfilment Terms:** Payment and Delivery Methods, two optional properties defined by the initial request, are checked by a fulfilment rule and if they match with the offers' available methods, their value is set to 1, otherwise to 0.
- **Ontology Info:** The Certification possession and the corresponding value (0 or 1) and the Rating of a Business Entity (1 to 5) according to the marketplace.
- **User Preferences:** The relative importance of the criteria defined by the user.

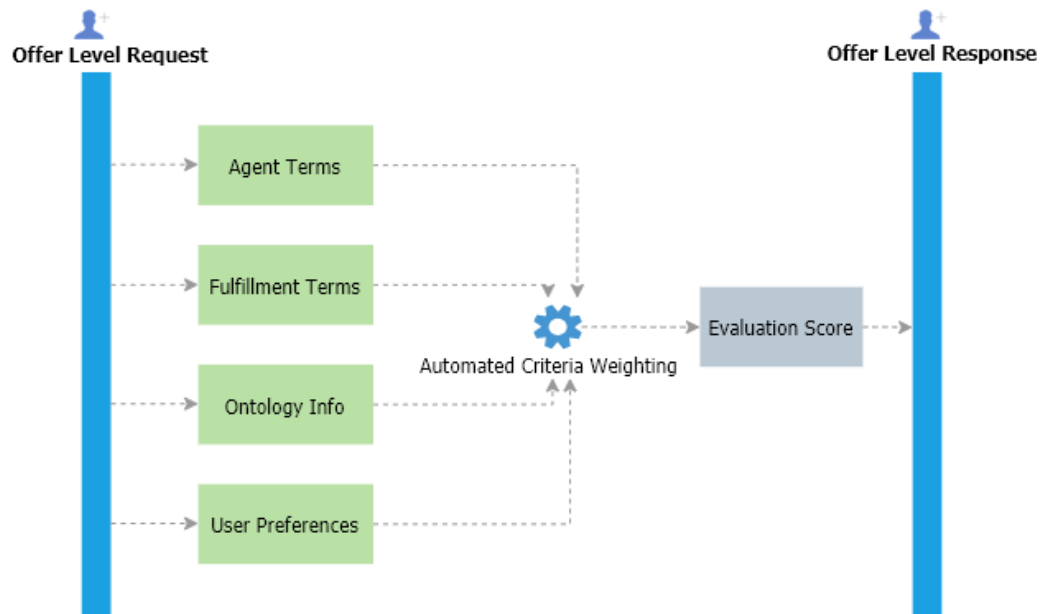

Figure 21. Offer Level Matchmaking Process

Each criterion owns a weighting factor, defined by the end-user, and a multi-criteria decision-making method is being implemented, the Analytic Hierarchy Process (Saaty, 1994). The key advantage of this method is the automated evaluation of the criteria based on the preferences provided by the user. Once the criteria weights are calculated, each alternative offer gains a weighted score, with the best one indicating the best offer. The user selects the order of preferences among all the available criteria with the first being the most important and the last being the least important. Weighted scores for each offer are then calculated and the best score indicates the best offer.

## 2 Business and Network Intelligence Gathering and Propagation

### 2.1 Introduction – Data, Analytics and Intelligence

This section presents the key concepts related to the business and network intelligence services of the EFPF ecosystem. The sub-sections describe the methodology used to develop, these tools and service as well as their benefit to the end user.

Standards and best practices are followed where appropriate as described in the following subchapters. In addition, the project partners have met and contributed to discussions that helped produce and refine the intelligence component.

Data is core to all modern manufacturing processes and increasingly becoming even more important in driving productivity for manufacturers. Every stage of traditional value chain is demanding more data and increased digital connectivity from their peers and partners.

#### 2.1.1 Data

It is important to understand what we mean by ‘data’ here for manufacturers and other related businesses. The following sections will explain the breadth of this ‘data’ using a few examples.

Manufacturers use a range of data to inform their decision making. This includes shop floor data from the machines, production control systems, IoT devices likes sensors etc. Collection and analysis of such data is largely useful in improving efficiency and reducing wastage / losses due to oversight or bad management. For example, by measuring the down time on machines between jobs, the owner can calculate the overall equipment efficiency. And that can further lead to some actions such as trying to bring the OEE to get a better return on the investment in this machine.

Similarly, ‘data’ can also include information stream coming from process management software like CRM (customer relationship management), SRM (supplier relationship management), PLM etc. Analysis of this information will provide an understanding of resource commitment and planning. Based on this analysis a company can try to mitigate potential operational risks such as being ‘undermanned on project’ and ‘not being able to deliver customer request on time’ to name a few.

And finally, there are other forms of ‘data’ that help manufacturers make business decisions such as ‘whom should I contract this work to?’, ‘what are my competitors doing?’, ‘How can I find more work with companies near me?’ Such data can include information about the organisational make up, supply chain connections, market and industry information through media channels etc. For example, by mapping and understanding the sub-tier suppliers, the manufacturer can keep a closer relationship and ensure compliance as well as coordinate deliveries. This can realise a massive benefit for the customer as it allows them to implement supply chain concepts such as ‘just in time’ which helps reduced the need for big inventories and frees up capital for growth.

## 2.1.2 Analytics

When this 'data' is systematically computed to discover, interpret and communicate meaningful patterns in information it is usually known as analytics. Analytics is a powerful tool and has been used by manufacturers for a long time. Traditionally done on graph sheets and physical paper, there are now several advanced digital tools that enable analytics for these companies.

After discovering meaningful patterns using analytics, the next step is to make informed decisions and generate (enabling or mitigating) actions. Therefore, analytics can be understood as an essential bridge between data and informed decision making.

## 2.1.3 Intelligence

Business & Network Intelligence typically refers to two distinct areas, the first of which being Business Intelligence (BI). Traditionally, BI refers to the processes that take place with the use of software systems to gain increased insight, knowledge and actionable intelligence into a particular area. The actionable intelligence is provided through data analysis, reports and data visualisations to better inform the strategic, tactical and operational decisions a business may encounter (Lans, 2012). The second area covered by the term is Network Intelligence (NI), conventionally, NI can be seen to refer to the variety of techniques and software systems that can be used to perform the monitoring and analysis of IP packets and other network information to gain an increased insight and intelligence into the flow of traffic that takes place within a network (Thorpe, 2019). However, in the context of EFPP, NI can also be seen as the analysis of connections that form within a network of organisations, such as within a supply chain. The Business and Network Intelligence Service within the EFPP platform offers a range of solutions for different needs with one such solution being Platform and Network Intelligence. This solution provides insight into the usage of the EFPP platform, its traffic flow and the networks of companies formed within the platform.

Intelligence in this context is the act of generating 'actionable insights' from the data. It helps organisations to take optimum actions that can bring maximum benefit subject to modelled constraints. For example, if a supplier is partly dependent on the aerospace industry and their advanced software picks up several news articles that are suggesting the decline in aerospace demand due to the onset of a large-scale pandemic. The intelligence software will gather analytics from multiple sources and combine it to arrive at a suggestion / action. In this case, the intelligence module might check the WIP (work in progress) levels for all aerospace orders, order book to identify the aerospace orders booked and the financial analytics to calculate the amount and its percentage of total value and highlight this as a risk citing that the dependence on aerospace production is over 50%. You need to reduce it to 30% to avoid cash flow problems in the next 3 months.

This allows the manufacturer to follow the actionable insight surfaced by their intelligence software/module while having the ability to audit the input analytics and modelled dependencies. Since the real world is a lot more dynamic than a software module can anticipate, the manufacturer can choose to modify or abandon the action suggestion all together. However, it does provide an ability to delegate tasks that require cognitive skills, traditionally reserved for humans.

Such modules are extremely popular in the supply chain industry where these systems are known as 'supply chain event monitoring and alert management' systems.

## 2.2 Scope and Relationship with other EFPF components

The aim of this task in the EFPF ecosystem is to promote interoperability between disparate digital tools, services and platforms by providing a component for intelligence services related to their business activities. EFPF is poised to become a massive ecosystem with all its core platforms and tools and their users coming together. This is a great opportunity to access, analyse and generate insights from this congregation.

The scope of tools and services introduced as a part of this module is limited to using openly available information scraped from the internet, metadata collected from the users and their activities on the platform and some other forms of data (factory machine data, ERP data, CRM data etc.) uploaded by the users to be combined with other streams and add more value, if any.

This task follows EFPF standard terms and conditions, user licence agreement and GDPR policy and guidelines. As a result, no personally identified information is acquired or used without prior consent of that party.

The EFPF consortium has decided to offer multiple tools under this component (explained in detail under subchapter 2.4 Tools and Services) to address a range of needs for European manufacturers. Each of these tools work to their own scope of data input, analysis and outcomes which is discussed in greater details in subchapter 2.4 and further subsections.

### 2.2.1 Relationship with other EFPF components

#### 2.2.1.1 With Matchmaking

Business and Network Intelligence and Matchmaking share a close relationship. It is important to analyse the purchasing and search demographics within the EFPF ecosystem to understand the market trends and promote matching products and services to the suitable clients. Furthermore, the data gathered in matchmaking and associated network intelligence will be reused in matchmaking to offer personalized recommendations and suggestions to the portal users.

The user's event data captured from the marketplace, federated search and related matchmaking functionalities are utilized effectively to generate Business and Network Intelligence. Many KPIs in the BNI dashboard are derived from search event data -Top 10 searched companies and products, highest searched base platform. to name a few.

The data from all connected platforms, tools and services flows into the federated search index as a result of the indexing workflows set up in matchmaking task. When a search is made on the portal, it is logged as an event in the 'search activity log index (ELK)'. This log index or ELK stack serves as a source of information for the Business & Network Intelligence component. The ELK stack serves as the main storage for this component as well.

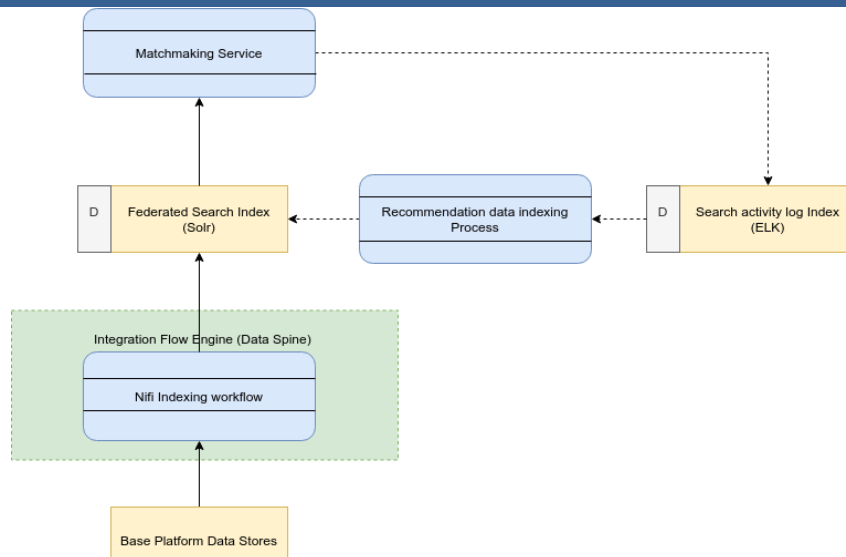

Figure 22. Data flow in EFPF Matchmaking Component

### 2.2.1.2 With EFPF Portal

All Business and Network Intelligence solutions discussed in this chapter are made available to the user through the EFPF Portal. Business and Network Intelligence have a dedicated ‘Value Proposition’ page, under which individual solution pages will be made available.

### 2.2.1.3 With other EFPF Components

The architecture diagram shown in figure 23 also illustrates the relationship to other components in which it interacts. The input to the solution can be seen on the left of the diagram with platform usage data coming from the EFPF Accountancy Service through the EFPF Data Spine. The visualisations produced and present within Kibana are then displayed as a dashboard within the EFPF Portal.

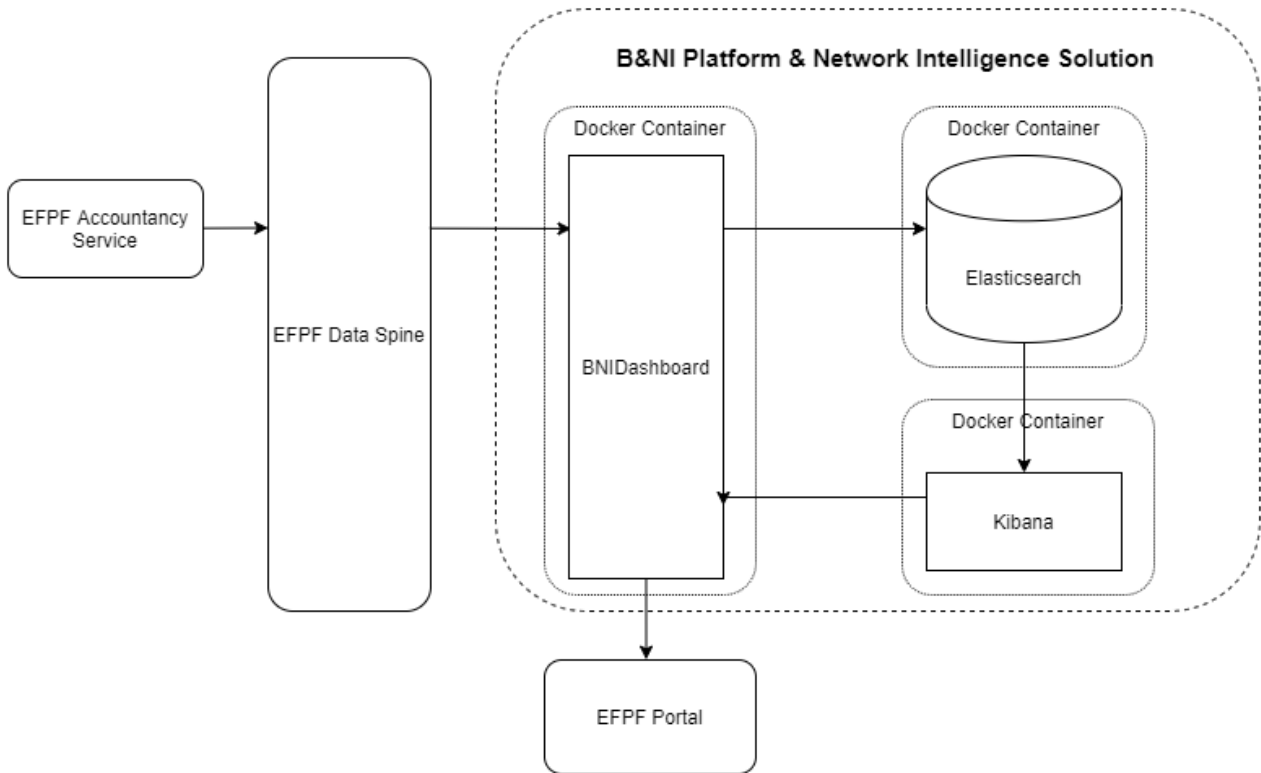

Figure 23. Platform and Network Intelligence Solution architecture diagram

## 2.3 Requirements for Business and Network Intelligence

Before we dwell on the details of this task, it is important to understand the context behind the introduction of this module to EFPF ecosystem. A number of requirements gathered from our pilot partners as well as experience and best practices from previous projects have contributed towards the requirements for this task.

Within the initial stages of the EFPF project, requirements elicitation took place in collaboration with the project’s user partners. This process identified specific requirements of the platforms intended user base in the form of User Stories, with several highlighting the need for a business and network intelligence solution. The user stories identified were then analysed and grouped as tasks within higher level scenarios in the form of epics. Both user stories and epics that have been identified in relation to business and network intelligence can be seen in Figure 24 below. From the user requirement scenarios shown, user stories EF-296, EF-297 and EF-298 are tasks within epic EF-A8 and user stories EF-299, EF-300 and EF-301 are tasks within EF-A5. The user requirements collected were then analysed to determine the technical requirements (see Figure 25) of the business and network intelligence solution needed.

Type	Jira Details	Description
User Story	EF-296	I want to view the most searched keywords in the EFPF Platform
User Story	EF-297	I want to view the most searched products in the EFPF Platform



User Story	EF298	I want to view the most searched companies in the EFPF Platform
User Story	EF299	I want to view company specific data
User Story	EF-300	I want to view the most searched products in a company's catalogue
User Story	EF-301	I want to view the status of all products and services within a company's catalogue
EPIC	EF-A5	As a Sales Manager I need a "cockpit" that offers me KPIs and other important information and notification about my catalogue to be informed about my performance and the correctness of information.
EPIC	EF-A8	As Marketing Manager, I aim to receive information about upcoming trends at the earliest possible, so that I can develop and design products, and bring them as quick as possible on the market. For SMEs this is extremely important, because they usually do not have separate market analysis departments

Figure 24. Business and Network Intelligence User Requirements

Type	Description
Technical	Capture platform data from the Data Spine
Technical	Use AI inspired analytic techniques to analyse the captured data and extract intelligence
Technical	Provide a dashboard to the platforms users to propagate intelligence gathered

Figure 25. Business and Network Intelligence Technical Requirements

In addition to the above requirements, the following generic scenarios were discussed by project partners which also contributed to the overall requirements followed in this task. These scenarios are inspired by some of the ancillary decision points that manufacturers have to follow ahead of collaborating in supply chains. A brief description on some of these has been provided below to for context and relevance.

- How can I generate more intelligence from my internal data (shop floor/ERP...) without committing to single expensive solutions built for large scale deployment?

European SME's are faced with an incredible challenge when adopting digital technology. Advanced business intelligence software modules are expensive to subscribe, complex to operate and have a big cost associated to their implementation. The vision of creating a ubiquitous platform meant that it should provide simple modules that can be used by all companies over the internet (easily accessible), eliminating the need for expensive implementation and allowing interoperability between different software tools on EFPF portal.

- Visibility – Europe is big!

Europe is the second largest manufacturing economy in the world. There are roughly two million manufacturing SME's (small and medium enterprise) in the European Union (Vladimirov, 2017). EFPF is a digital platform enabling connectivity between these European manufacturers. It is impossible to know and understand all the capabilities of all manufacturing companies in the EU. Companies need this information to acknowledge, partner, buy/supply or compete with each other. Therefore, in order to facilitate



matchmaking (see chapter on matchmaking - Matchmaking) and other business decisions the platform should enable channels through which more intelligence can be gathered and used for decision making.

- What information can I generate from the activity of others on EFPF platform?

There is great potential to harness the metadata associated with the activities and engagement of EFPF users on this platform into actionable insights or intelligence. This can better inform the decision making, strategy and future engagements. For example, a manufacturing SME could use such a service to understand the demand for products that are similar or complimentary/supplementary to their offering. The SME can use this information to narrow down to the companies actively searching for these products/services on the platform and connect with them directly with aim of doing more business with them. In this example, the manufacturer/user of the platform is able to access metadata from the platform activity, analyse and filter it to give them actionable insights into the trends by region, industry or sector.

- Can I generate intelligence directly from other users?

Often, the best source of insightful data comes from other companies directly. This is a common practice in the industry and is usually done through audits, surveys and/or questionnaires which are widely known. Pushing the agenda of bringing European manufacturers closer over a digital platform, a need was felt to introduce a service that could enable you to build consortiums/networks based on the capability information available for those businesses. Within this consortium, the user can build and publish surveys (mining intelligence) and audits (ensuring compliance) and get meaningful information directly from other EFPF users. This information can be visualised in the form of reports and charts that can easily be shared or distributed across supply chains. Subchapter – Execution and Pilot Case Studies presents a detailed account of this use case.

## 2.4 Tools and Services

The business and network intelligence task focused on identifying and catering to the applications of this service for different levels of engagement of a company. To simplify it further, the partners have decided to compartmentalise the tools and services under this task into three distinct levels:

- Intracompany level – Aims to generate actionable intelligence from activities and processes within a company. This category is to do with generating and sharing intelligence for work done within the organisation.
- Platform/Network level – Aims to generate intelligence from the existing networks that a company is already involved in as part of their supply chains and other business activities. This category is to do with analysing all work that goes on in the existing networks of a company.
- Market Intelligence – Aims to provide intelligence about the general market the organisation works in. This category includes all entities that might not directly be known to / linked to your organisation but their activities in the industry/geographical area/sector of interest provides useful insights and trends. In other words, this goes beyond a company's internal operations and existing networks (both digital and physical).

## 2.4.1 Intracompany Level Intelligence Services

Modern day manufacturer is collecting huge amounts of data from their internal systems (production control systems, project management systems, CRM systems etc.). There is a pressing need to digest this information and produce meaningful insights that will help the manufacturer in better decision making for their company's progress.

The tools/services introduced under this category are focused on helping manufacturers use digital tools that can be accessed through EFPP platform, are simple to use and provide key insights towards a certain goal. An example could be analysis of machine usage data, along with sales pipeline data and inventory levels et al to optimise the cashflow for a manufacturer.

### 2.4.1.1 Production KPIs

In order to implement process improvement strategies within manufacturing environments its vital to have an agreed set of metrics or key performance indicators (KPI). This can then be used as a benchmark to gauge the degree of improvement as a result of changes to the process. Common examples of this types of Manufacturing Business Intelligence are listed below:

- Manufacturing Cycle Time
- Overall Equipment Effectiveness (OEE)
- Overall Throughput Effectiveness (OTE)
- Production Yield Rates by Product, Process and Plant Location
- Perfect Order Performance
- Return Material Authorizations (RMA)

OEE is common place in the manufacturing domain and is concerned with measuring the overall performance of a given machine, product line or work centre. OEE is calculated using the formula of Availability \* Performance \* Quality and is considered an accessible metric for tracking production performance to the machine and plant floor level since it is easy to calculate and easy to evaluate resultant improvements.

The potential to share KPI metrics, such as those described above, within an organisation and potentially between manufacturing sites would be a valuable indicator to support management and strategic planning. The goal in EFPP is to offer one or more KPI based on the manufacturing data made available within the project pilots.

**Waste Monitoring Intelligence:** The potential to gain Business Intelligence from the waste generated from the production processes. This is particularly important from the environmental perspective but also from the financial view point as waste can be an indicator for inefficiency within processes, and also a generator of revenue as the material can be purchased by a waste recycling supplier. It is considered within EFPP to use the data from monitoring of waste levels to automatically track bin fill levels and compare local suppliers to find the best price.

This will offer benefits for both customer and supplier. Suppliers will be able to track businesses within a perimeter that all require the same waste disposal. Whereas, customers will have the opportunity to monitor waste identify patterns in waste generation that can be fed back into their production process.

**Factory Environment Monitoring:** Manufacturing effectiveness can be dependent on numerous external factors including those which are environmental. Machines and processes particularly in sectors where high tolerances are adhered to can be subject to variations which affect quality and therefore waste when environmental variations occur within the factory,

An example of this in practice would be within aerospace industry where temperature affects the metal materials used to fabricate the parts by causing thermal expansion. Since tolerances are extremely high (in the microns range) this can have a significant impact and needs to be factored in when producing. To reduce any issue with incorrect parts, live data could be married with predictive weather and forecasted temperature data to provide Business Intelligence that could later be automatically fed back into the parameters of the process. Initially this can be carried out by manual adjustment of parameters, but the goal would be to adjust parameters automatically.

### 2.4.2 Platform/Network Level Intelligence Services

Another application of intelligence is in outwards facing business decisions that manufacturers have to make in their networks. An example of this network could be the existing supply chain relationships. The manufacturer will have a great relationship with immediate suppliers and/or customers. The manufacturer can leverage this personal relationship to collect information (for example, about forecasted demand, changed lead times, new product introduction etc.) that will help them plan ahead and plan better. However, since there is no direct relationship with the other actors in this supply chain (manufacturing supply chain can span across multiple tiers comprising of thousands of suppliers) it is difficult for the manufacturer to collect information, analyse it and get any indication of a possible knock on effect from their actions. In an attempt to solve this, a couple of tools have been introduced in this category that address these challenges in different ways. A description of the scope, maturity level and application of these tools has been provided below:

#### 2.4.2.1 EFPF Platform & Network Intelligence Solution

The EFPF Platform & Network Intelligence solution collects data around the usage of and traffic flow within the EFPF platform. Through the collection and analysis of both the search events and login events that take place within the platform, the insights gained from the analysis are visualised and presented within a dashboard in the EFPF portal. This enables users to gain intelligence not only about the trends within the EFPF platform, but also within its ecosystem of connected platforms through the Federated Search feature.

**Technologies:** The Platform & Network Intelligence Solution is composed of several technologies and components which have been identified in Figure 26. As shown below, the solution consists of Elasticsearch and Kibana to store and visualise the data respectively, and also the BNI Dashboard application which has been developed with the use of Java, Maven and docker to provide the solution with a back end to source all required data.

Component / Technology	Type	Version	Description
Elasticsearch	Search Engine / Data Store	7.6.0	Elasticsearch is a distributed, RESTful search and analytics engine which is used to both analyse the data ingested into the solution and acts as a Data Store for the solution. This is deployed in the form of

			a docker container.
Kibana	Data Visualisation Tool	7.6.0	Kibana is a Visualisation tool that is used within the solution to visualise the data that is ingested into Elasticsearch. This is deployed in the form a docker container.
BNIDashboard	Web Application	1	The BNIDashboard is a web application that has been developed to first provide a backend to the solution, retrieving the platforms search and login events, then passing the data to Elasticsearch. The application also provides the solutions front end in the form of a Kibana dashboard which is displayed within the EFPF Portal. This is deployed in the form of a docker container.
Java	Language	1.8.0_191	Java is the programming language used within the development of the BNIDashboard application.
Maven	Dependency Management	3.6.0	The Dependency Management System used within the BNIDashboard application
Docker	Docker Engine Docker Compose	19.03.5 1.17.1	Docker and docker-compose are used to deploy and host Elasticsearch & Kibana and the BNIDashboard application.

Figure 26. Platform and Network Intelligence Solution Technologies

**Architecture:** To illustrate the architecture of the Platform & Network Intelligence Solution, the solutions architecture Diagram has been included (Figure 27). The diagram shows that the solution consists of three core components; Elasticsearch and Kibana which are existing technology solutions and the BNI Dashboard which has been developed for the Platform and Intelligence Solution. As illustrated in the diagram, all components of the Platform and Network Intelligence Solution are deployed as docker containers.

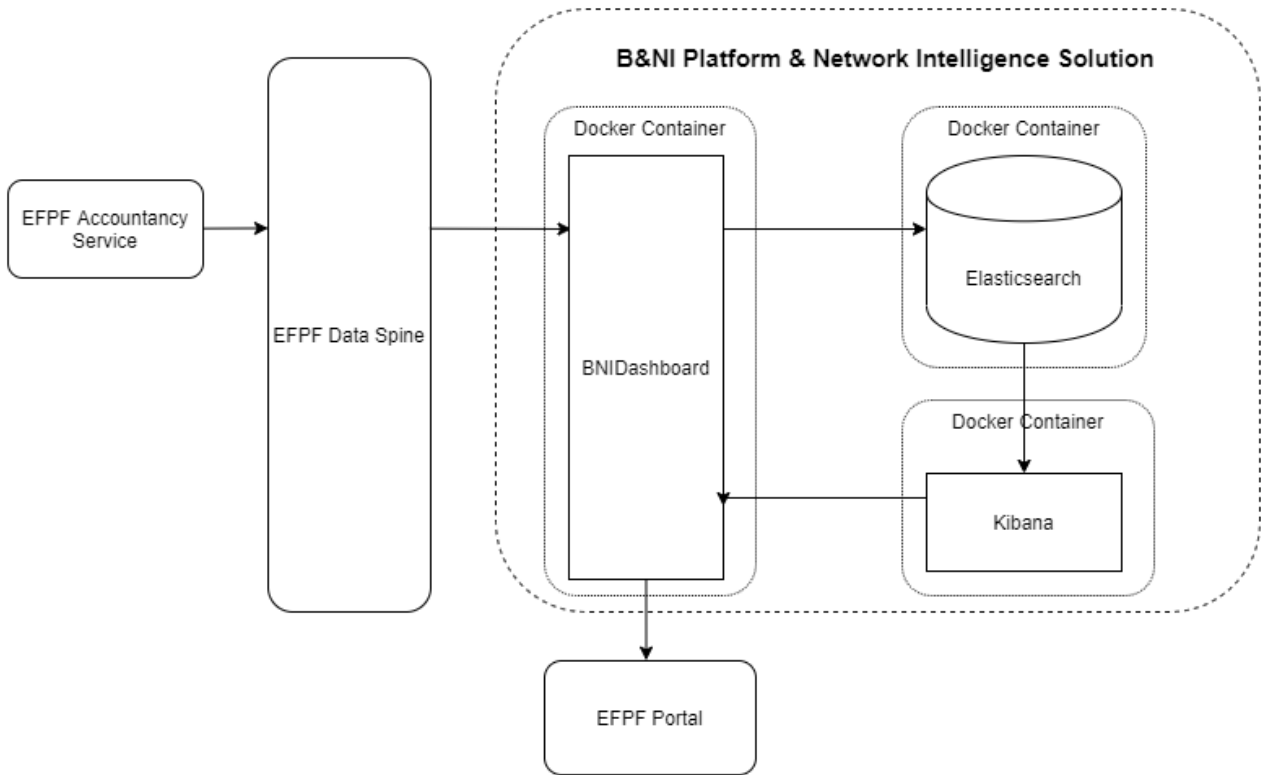

Figure 27. Platform and Network Intelligence Solution - Architecture Diagram

Within the Platform and Network Intelligence solution, Elasticsearch is used as the data store for all search events. To further illustrate the construction of this data store, the schema or mapping used has been included. Each search event, in the form of a document, has been indexed into Elasticsearch with a nested structure. The documents indexed consist of data relating to the query request (Figure 28) and the query responses that have been returned for that request (Figure 29). As shown within the query response schema, the search responses for a particular request are nested so that only one schema is used.

```

{
  "properties": {
    "userId": { "type": "text", "fields": { "keyword": { "type": "keyword" } } },
    "searchType": { "type": "text", "fields": { "keyword": { "type": "keyword" } } },
    "query": { "type": "text", "fields": { "keyword": { "type": "keyword" } } },
    "tags": { "type": "text", "fields": { "keyword": { "type": "keyword" } } },
    "@version": { "type": "text", "fields": { "keyword": { "type": "keyword" } } },
    "platform": { "type": "text", "fields": { "keyword": { "type": "keyword" } } },
    "host": { "type": "text", "fields": { "keyword": { "type": "ip" } } },
    "@timestamp": { "type": "date" },
    "action": { "type": "text", "fields": { "keyword": { "type": "keyword" } } },
    "facetQuery": { "type": "text", "fields": { "keyword": { "type": "keyword" } } },
    "geo_x_real_ip": { "properties": { "continent_name": { "type": "text", "fields": { "keyword": { "type": "keyword" } } },
      "country_iso_code": { "type": "text", "fields": { "keyword": { "type": "keyword" } } },
      "location": { "type": "geo_point" } } },
    "headers": { "properties": { "http_accept": { "type": "text", "fields": { "keyword": { "type": "keyword" } } },
      "http_version": { "type": "text", "fields": { "keyword": { "type": "keyword" } } },
      "contenttype": { "type": "text", "fields": { "keyword": { "type": "keyword" } } },
      "http_user_agent": { "type": "text", "fields": { "keyword": { "type": "keyword" } } },
      "requestMethod": { "type": "text", "fields": { "keyword": { "type": "keyword" } } },
      "connection": { "type": "text", "fields": { "keyword": { "type": "keyword" } } },
      "http_host": { "type": "text", "fields": { "keyword": { "type": "keyword" } } },
      "request_path": { "type": "text", "fields": { "keyword": { "type": "keyword" } } },
      "content_length": { "type": "text", "fields": { "keyword": { "type": "integer" } } },
      "content_type": { "type": "text", "fields": { "keyword": { "type": "text" } } },
      "x_real_ip": { "type": "text", "fields": { "keyword": { "type": "ip" } } } } },
    "searchResponse": { "type": "nested", "properties": { <SEARCH-RESPONSE-DOCUMENTS> } }
  }
}
    
```

Figure 28. Platform and Network Intelligence Solution Query Request Schema

```

"searchResponse": {
  "type": "nested",
  "properties": {
    "uri": {"type": "text"...},
    "code": {"type": "text"...},
    "localName": {"type": "text"...},
    "nameSpace": {"type": "text"...},
    "languages": {"type": "text"...},
    "label": {...},
    "alternateLabel": {"type": "text"...},
    "hiddenLabel": {"type": "text"...},
    "description": {...},
    "comment": {"type": "text"...},
    "basePlatform": {"type": "text"...},
    "catalogueId": {"type": "text"...},
    "applicableCountries": {"type": "text"...},
    "freeOfCharge": {"type": "boolean"...},
    "certificateType": {...},
    "deliveryTime": {"type": "object"...},
    "packageAmounts": {"type": "object"...},
    "manufacturerId": {"type": "text"...},
    "manufacturerItemId": {"type": "text"...},
    "serviceType": {"type": "text"...},
    "supportedProductNature": {"type": "text"...},
    "supportedCargoType": {"type": "text"...},
    "emissionStandard": {"type": "text"...},
    "classificationUri": {"type": "text"...},
    "stringValue": {"type": "object"...},
    "booleanValue": {"type": "object"...},
    "doubleValue": {"type": "object"...},
    "imageUri": {"type": "text"...},
    "incoterms": {"type": "text"...},
    "minimumOrderQuantity": {"type": "text"...},
    "warrantyValidityPeriod": {"type": "text"...},
    "classification": {"type": "text"...},
    "manufacturer": {...},
    "customProperties": {"type": "text"...},
    "currency": {"type": "text"...},
    "packageUnits": {"type": "text"...},
    "price": {"type": "object"...},
    "deliveryTimeUnits": {"type": "text"...},
    "legalName": {"type": "text"...},
    "brandName": {"type": "object"...},
    "origin": {...},
    "ppapComplianceLevel": {"type": "text"...},
    "ppapDocumentType": {"type": "text"...},
    "trustScore": {"type": "text"...},
    "trustRating": {"type": "text"...},
    "trustTradingVolume": {"type": "text"...},
    "trustSellerCommunication": {"type": "text"...},
    "trustFullfillmentOfTerms": {"type": "text"...},
    "trustDeliveryPackaging": {"type": "text"...},
    "trustNumberOfTransactions": {"type": "text"...},
    "trustNumberOfEvaluations": {"type": "text"...},
    "logoId": {"type": "text"...},
    "businessType": {"type": "text"...},
    "activitySectors": {...},
    "businessKeywords": {...},
    "id": {"type": "text"...}
  }
}

```

Figure 29. Platform and Network Intelligence Solution Query Response Schema



**Functionality:** The platform and network intelligence dashboard available for the platform users has been included below and shows all the visualisations currently available to give the platforms users an insight into the ongoing trends. The individual visualisations will be further discussed below.

The dashboard for the platform and network intelligence solution has been included in Figure 30, and shows all the visualisations currently available for the platform users to gain an insight into the ongoing trends. Individual visualisation will be further discussed below.

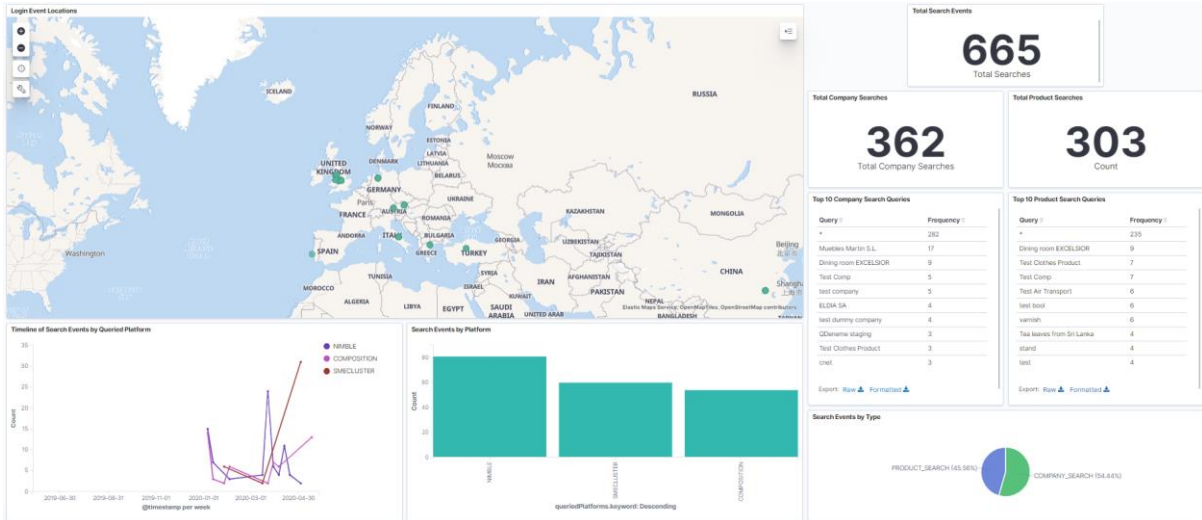

Figure 30. Platform and Network Intelligence Solution Dashboard

The map visualisation included in Figure 31 shows the geographic location of each login event that takes place within the EFPF platform, this allows users to understand where the platform’s user base is located.

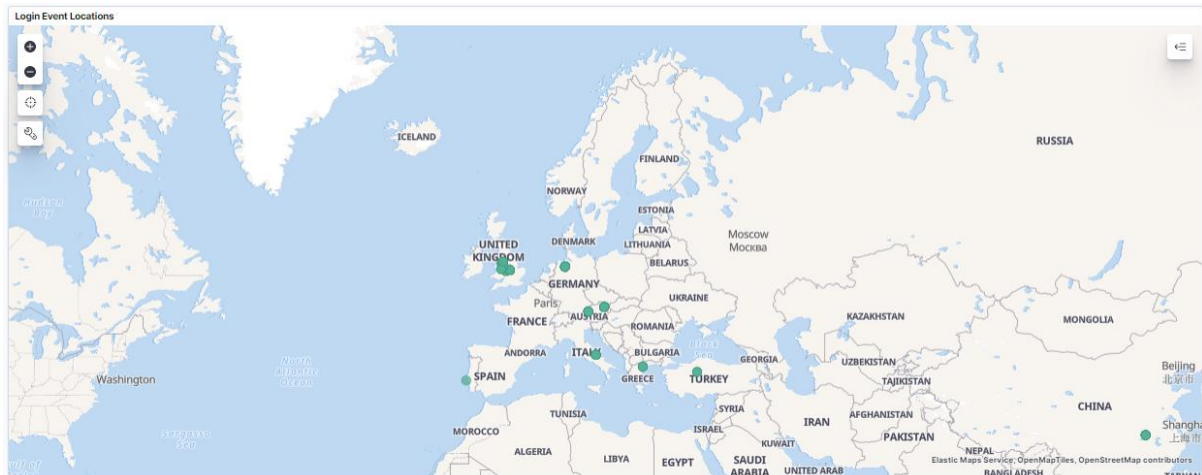

Figure 31. Platform and Network Intelligence Solution Map Visualisation

The three metric visualisations present in the dashboard have been included in Figure 32, and illustrate the total number of search events that have taken place within the platform, and the total number of both product and company searches that have taken place. Through the application of filters on the data source the user can then refine the data. For example, by selecting the Nimble platform in another visualisation, the metrics will then display the total amount of searches in this base platform.



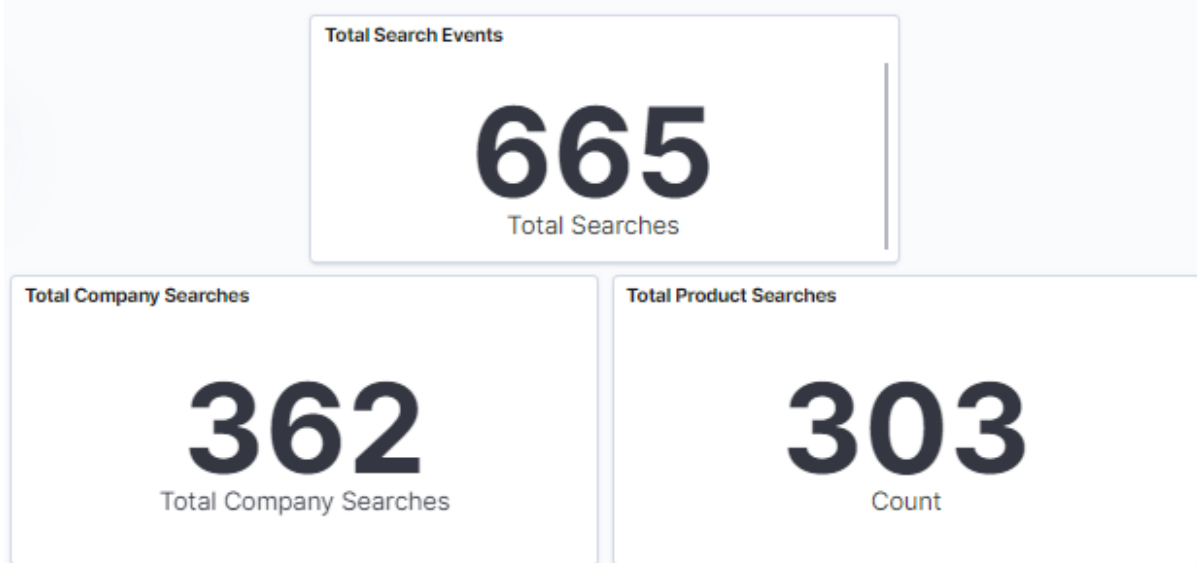

Figure 32. Platform and Network Intelligence Solution Metric Visualisations

The two top ten query visualisations present in the dashboard have been included in figure 33, and display the top ten most searched queries within both the product search and company search features of the EFPF platform. This allows the platforms users to view the ongoing trends within the EFPF platform to understand what it is the platforms users are searching for. Through the application of additional filters on the data source, the users can then refine this data. For example, a filter may be applied so that the visualisation displays the top ten searches that have taken place within the Nimble base platform.

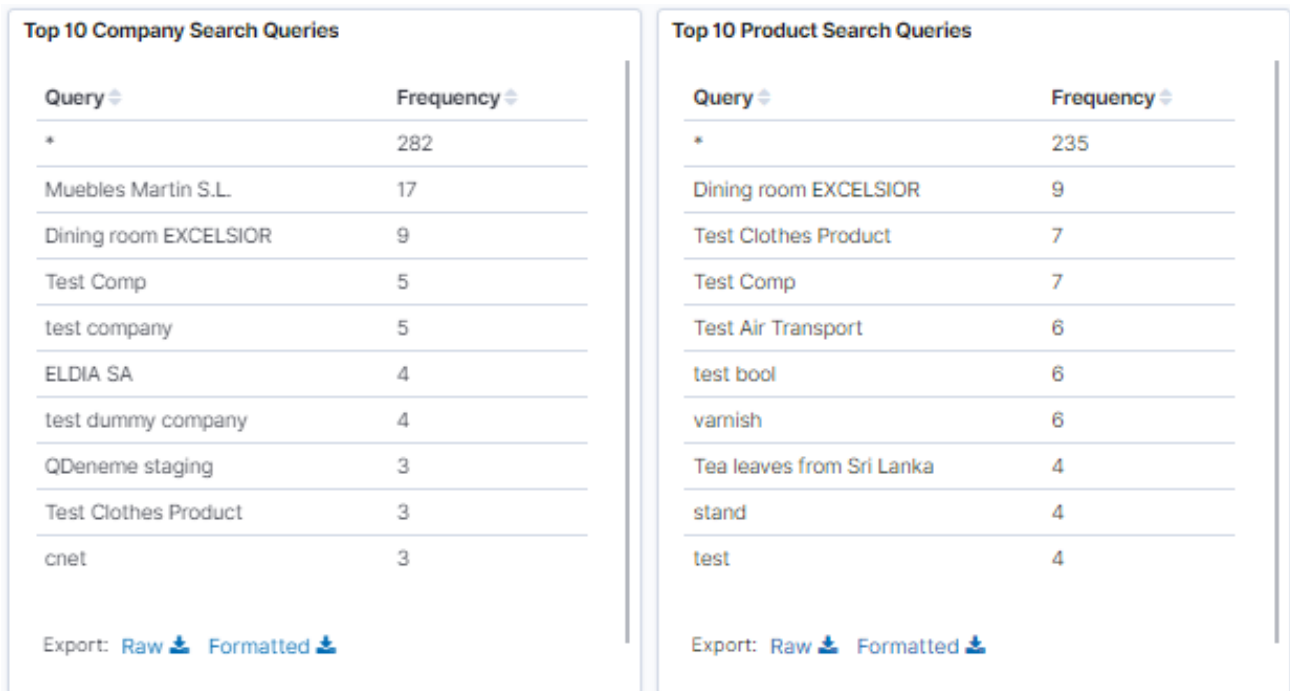

Figure 33. Platform and Network Intelligence Solution Top 10 Query Visualisations

The bar chart present in the dashboard has been included in figure 34, displays the number of search events that have taken place within each of the EFPF base platforms. This allows users to see which integrated platforms are currently trending within EFPF.

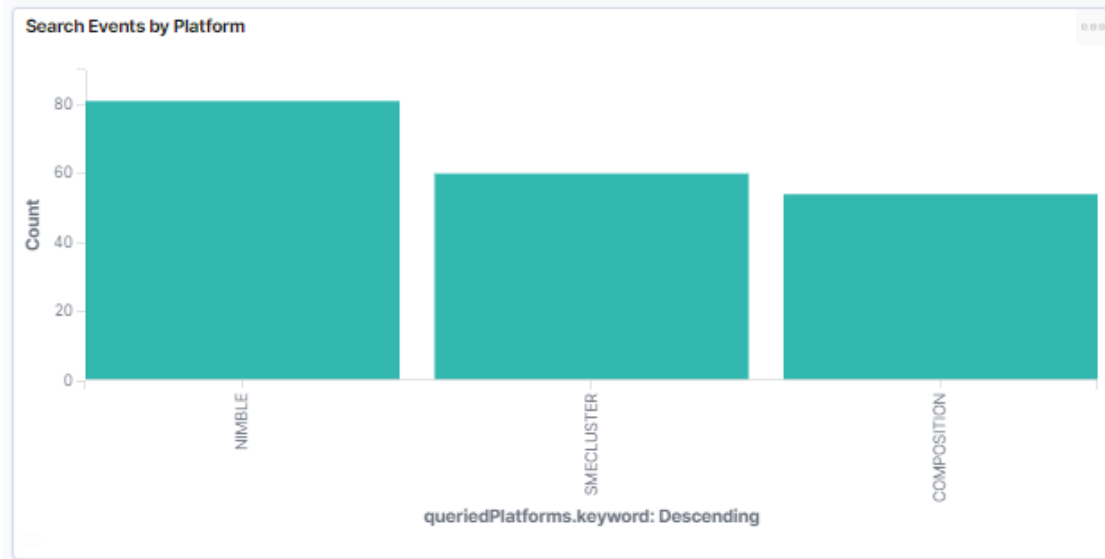

Figure 34. Platform and Network Intelligence Solution Search Events by Platform Visualisation

The pie chart present in the dashboard has been included in Figure 35 and displays the division of search events in the EFPF platform. It displays the proportion of search events that have taken place within both the product and company search features of the platform. This allows user of the platform to understand what other users are searching for within the platform.

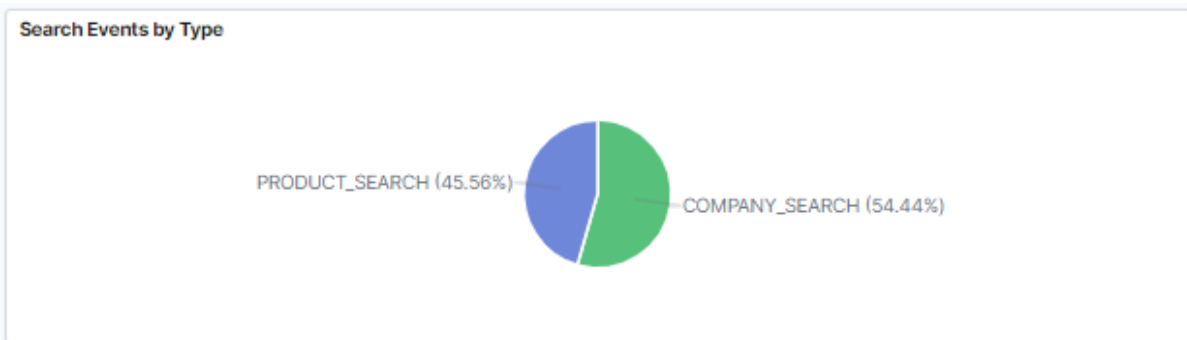

Figure 35. Platform and Network Intelligence Solution Search Events by Type Visualisation

The date histogram present in the dashboard has been included in figure 36 and illustrates the number of search events that have taken place within each of the base platforms across the course of the platform’s lifetime. This visualisation allows the platforms users to view the level of interaction in the platform at a given point in time.

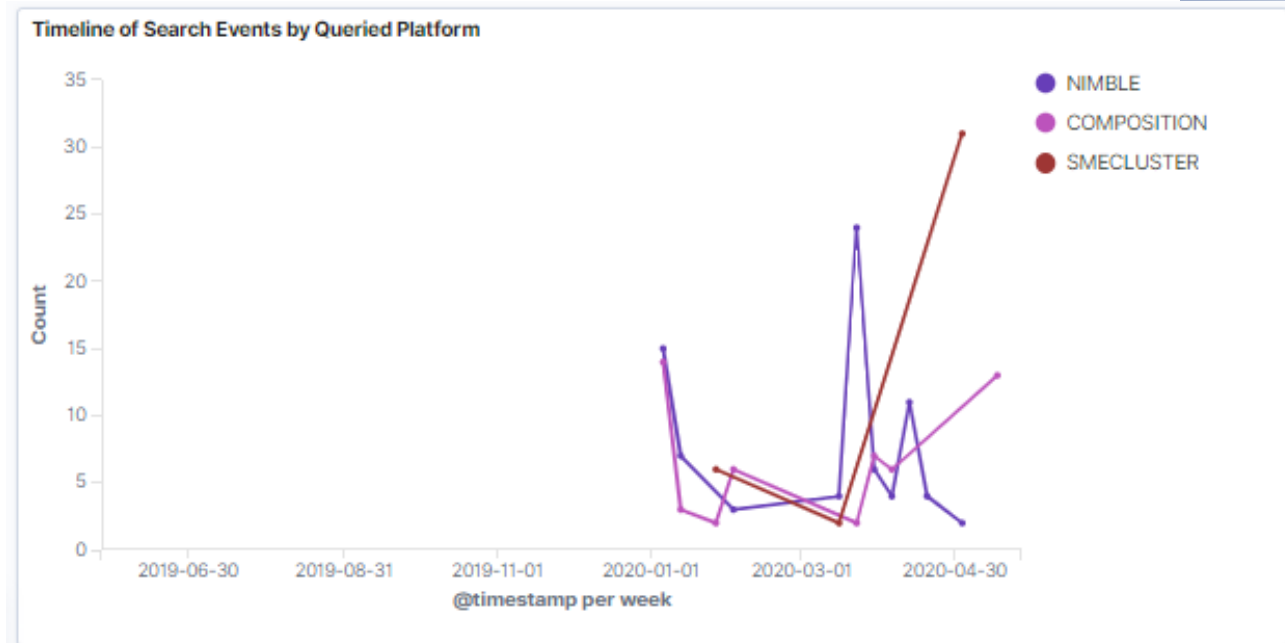

Figure 36. Platform and Network Intelligence Solution Date Histogram Visualisation

### 2.4.2.2 iQcluster Platform

iQcluster is a supply chain intelligence platform that is designed to facilitate supply chain visibility, easily share data and engage the lower tier supplier by creating a digital community. Unlike most platforms which are ‘one to many’ in design, iQcluster leverages its ‘many to many’ platform model to engage every stakeholder, big and small. The idea is to return some benefit to every company that joins and share data/information with the network. This creates a direct benefit to for each user and the benefit compounds as we move up the tiers of supply chain as this data aggregates and reflects unparalleled intelligence that is otherwise fragmented or unavailable.

iQcluster combines the conventional ‘top down’ supply chain mapping with an innovative ‘bottom up’ approach to address the gaps. iQcluster’s data science expertise creates a great take off platform by big data scrapping to identify key intelligence about companies in supply chain. Then, the suppliers are invited to join the platform and a unique incentivisation model is used to boost adoption rates. iQcluster offers freemium digital productivity tools (limited functionality CRM, digital auditing tools etc.) to drive engagement. iQcluster enables modelling and adoption of established diagnostic tools such as DRL – Digital Readiness Level, BUSex, MANex, Digital productivity tools (Valuechain IP), anti-slavery, conflict minerals etc. that can be used in the same network. This gives individual companies a benefit of measuring their readiness level, while it gives intelligence to their customers about their level and improvement over time. The benefit for the sub tier suppliers is the benchmarking or anonymous intelligence they receive back after sharing information in the network (filling out diagnostics, supplier benchmarking metrics etc.) which is a direct value for their business and perhaps a conduit into the bigger picture of the industry which they are usually very distant from. By actively joining the network, suppliers are promoting their capabilities and opening up to possibilities of more work (collaborative, funding, new projects). Hence the USP of iQcluster platform is to enable a community of suppliers where each get a win for their input and that enhances the chances of their engagement as well as getting more data to help understand the dynamics (and useful intelligence) better. Here is a link to iQcluster’s promotional video

which articulates the value proposition for its existing and prospective users - <https://youtu.be/zTCdGQ83CNs>.

iQcluster has been integrated as a 3rd party add-on to EFPF platform. iQcluster is currently available through the EFPF Portal under Business Intelligence section. EFPF users can seamlessly enter iQcluster platform through 'single sign on' (SSO). Prominent features of the platform are explained below:

**Creating a Network on iQcluster – Consortium Building:** Users can create a new network and invite members (suppliers, partners, association members etc.) The user goes through a 3-step setup wizard, which guides them through the set-up process. Figure 37 shows a screenshot of the network setup wizard form iQcluster platform.

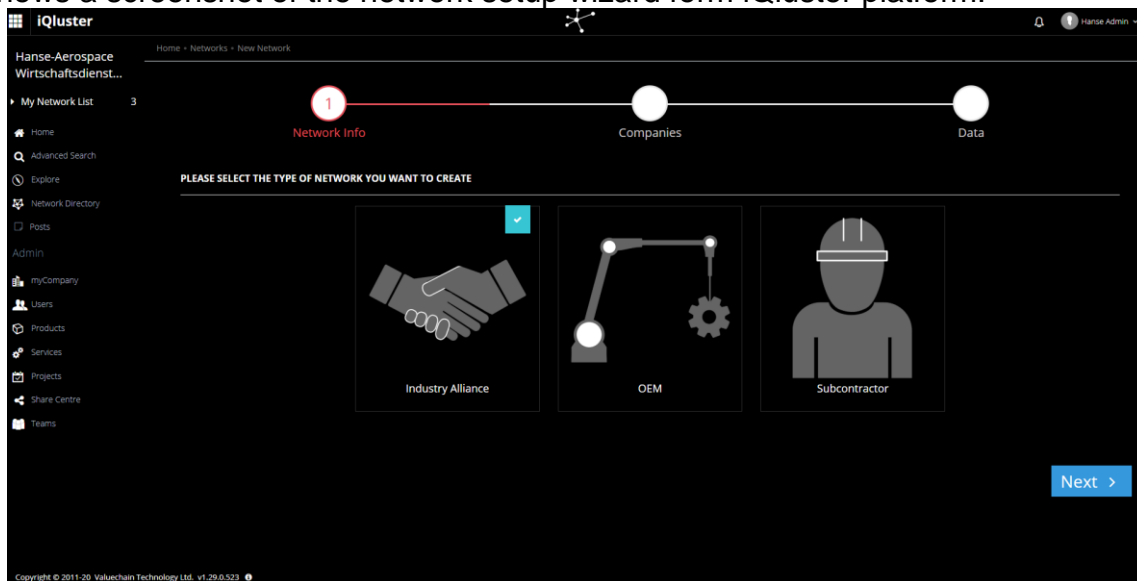

Figure 37. Network creation wizard in iQcluster

New members can always be added to the network after it is created by sending them an invite link under 'Companies Tab' figure 38.

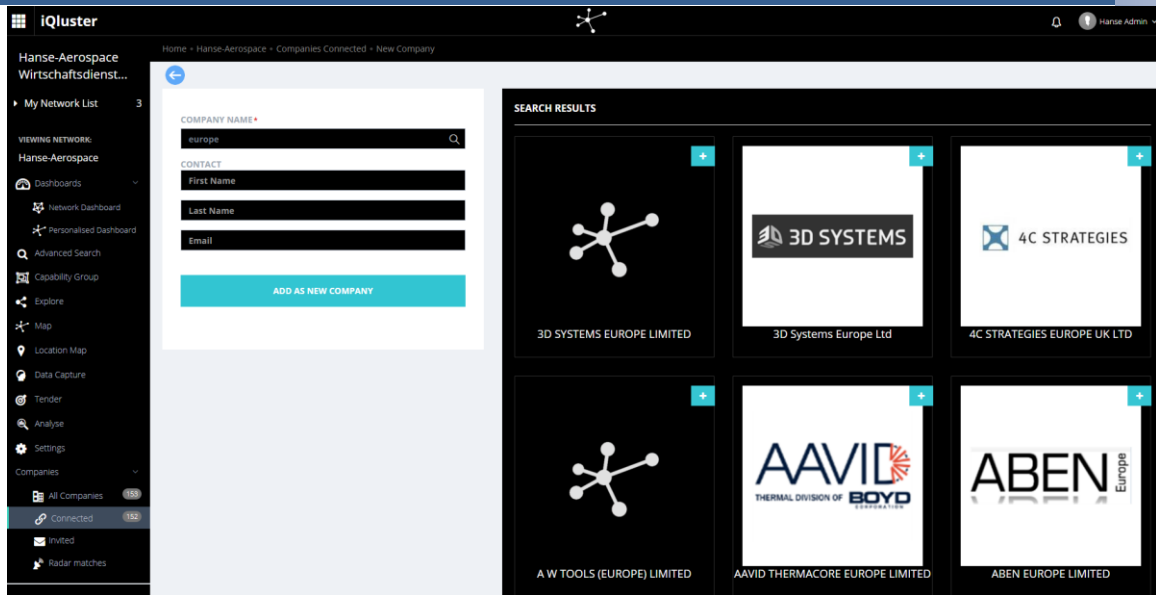

Figure 38. Inviting new companies to join iQluster network

Alternatively, user can browse through the ‘Network Directory’ which allows them to explore the wider platform and discover other existing networks. If the user finds a particular network of interest, they can view activity dashboard of that network to get a high-level understanding as well as data reflecting its engagement shown in figure 39. The user can then request to join that network, which is routed through to the network leader for approval before they are granted access.

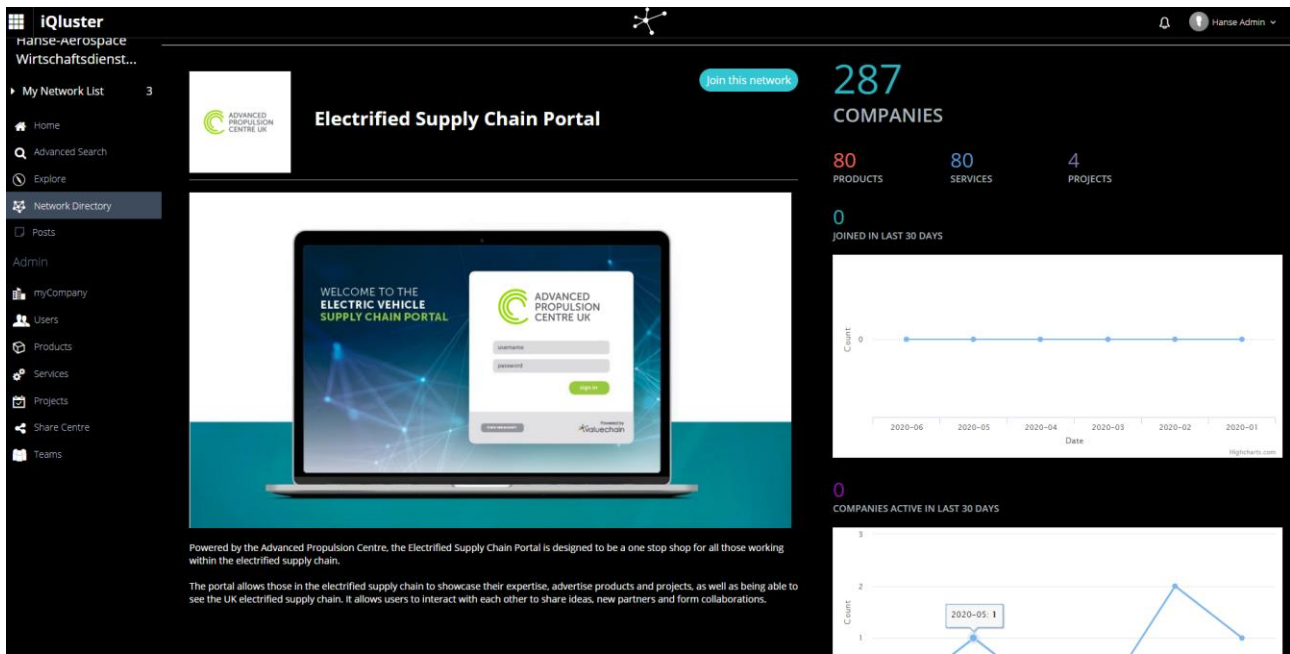

Figure 39. Network analytics and request to join – Network Directory

**Automated Data Collection on iQluster:** iQluster uses advanced web scraping algorithms that work to collect openly available information on companies. The algorithms are constantly looking for information that is deemed useful for manufacturing supply chains. Some of those categories are mentioned below:

- Alternate Company Addresses
- Certifications such as ‘ISO9001’ or ‘AS9100’
- Manufacturing Capabilities such as ‘Milling’ or ‘Machining’
- Technologies such as ‘Additive Manufacturing’
- Sectors such as ‘Aerospace’ or ‘Nuclear’
- Financial information

This information comes from a variety of open sources including websites, news feeds, social media as well as national company registers and other credit rating industries. It provides the user a great deal of intelligence on these companies. Therefore, iQluster acts as an intelligence engine which aims to capture as much useful information as is possible to continuously provide the user with updated information. A great example of this is presented in Hanse Aerospace’s network case study - Hanse Aerospace.

**Audit/Survey on iQluster:** iQluster provides a data capture feature embedded in the platform. The data capture module is simple yet powerful tool to generate intelligence from the network (consortium). Data Capture allows the network leader to curate Audits and surveys to capture information directly from the active network members. This further

enhances the information available on companies through web scraping providing a more complete understanding of the network.

The platform provides a range of preconfigured templates for standard audits such as 'ISO9001', 'AS9100', 'OHSAS18001', 'Business Excellence (BUSEx)' etc. Users can also quickly build their own custom audits or questionnaires. These questionnaires can be configured as scored assessment such that each question get marked automatically based on the answer, resulting in a final score. This makes it useful to analyse the scores achieved by different companies in the network while also enabling a trend analysis (for a scheduled recurring questionnaire) for that individual company. The questionnaires can be scheduled into the future and can be made recurring too.

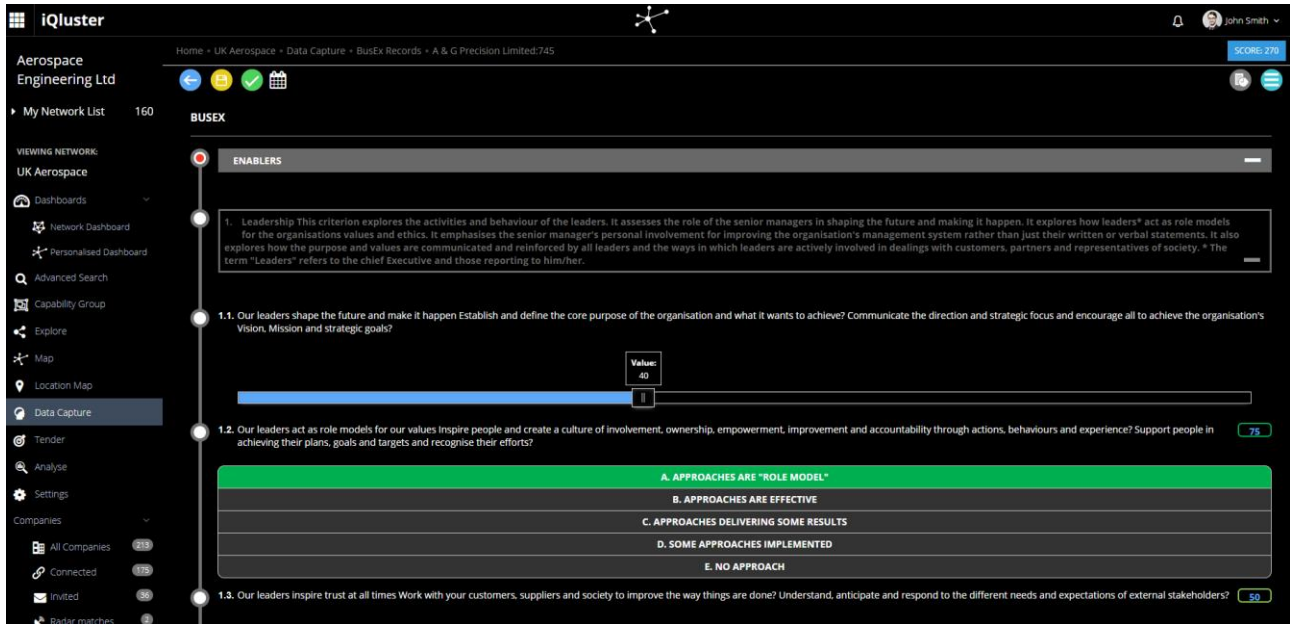

Figure 40. Example of preconfigured Business Excellence audit on iQluster platform

**Analysis and Visualisation on iQluster:** iQluster provides advance visualisation tools to bring out meaningful insights from the data collected in previous steps above. The advanced search provides ability to search for companies with any related information that the platform holds about them. For example, instead of typing company names, the user can type 'steel brackets' and all companies that say they do that will appear. The user can further filter the results by other attributes like 'region' or 'certifications' etc. Similarly, the user could not only search through the companies but also the products, services and projects in the network too. An example of this is provided in figure 41.



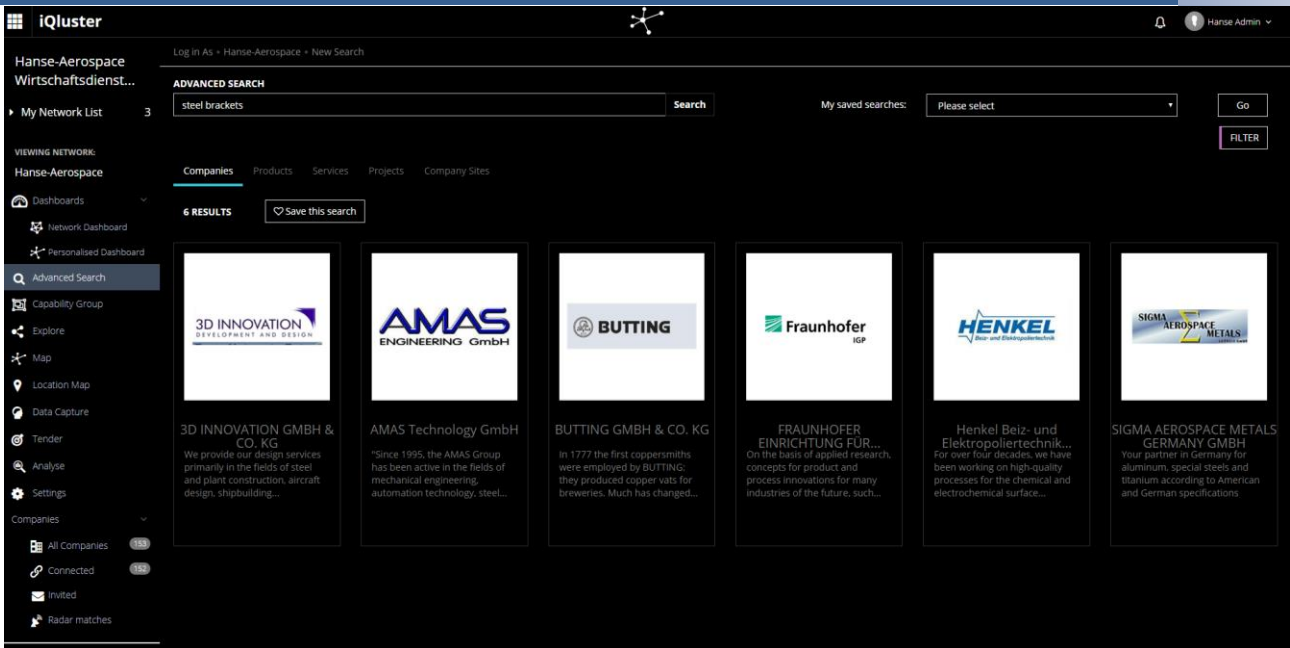

Figure 41. Advanced Search example in iQluster

Another visual module is the Explore Map. This is designed to use the intelligence generated in steps above and drill down into the network. This provides a structured method of exploring the companies as well as modelling and visualising supply chain connections. An example is provided in figure 42.

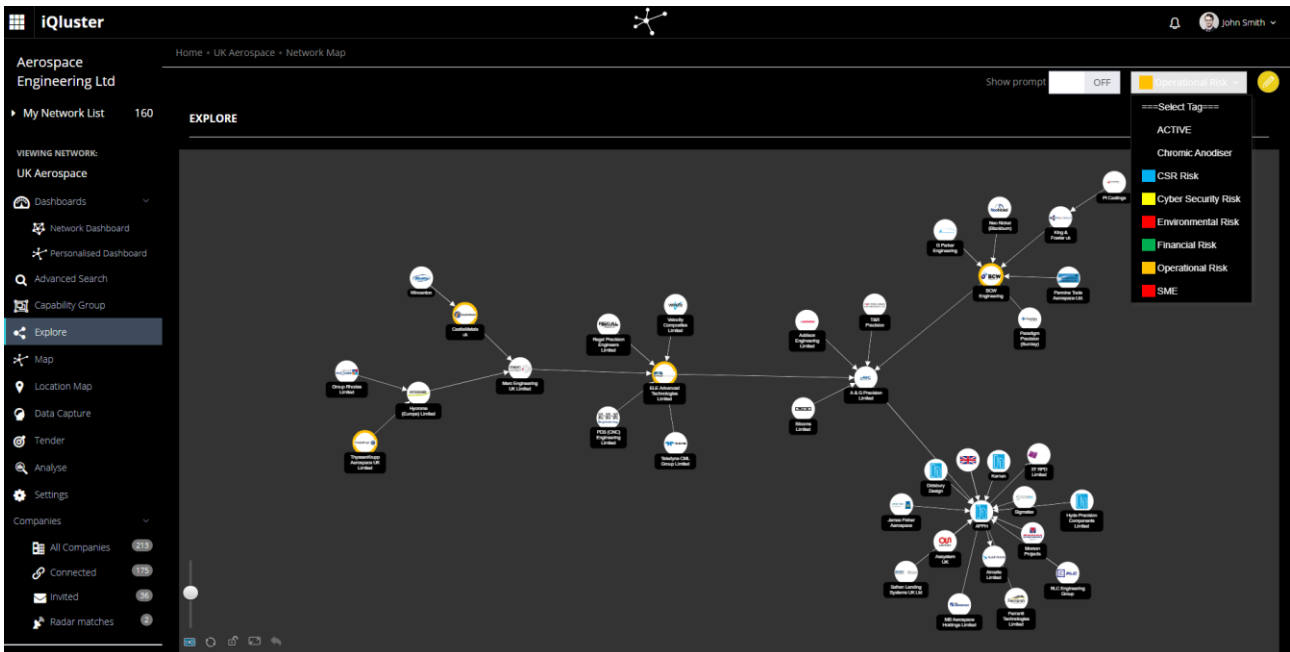

Figure 42. Supply Chain connection modelling in Explore Map

This module can also be integrated to websites and blogs to provide a window into the network and related intelligence. An example of this is demonstrated in Hanse Aerospace’s case study under section ‘Website integration’ - Hanse Aerospace.

iQluster provides configurable Dashboard that can be populated with analytics and reports generated using data collected in above steps. The reports are interactive and allow users to click through them to see underlying information. An example is shown in figure 43.

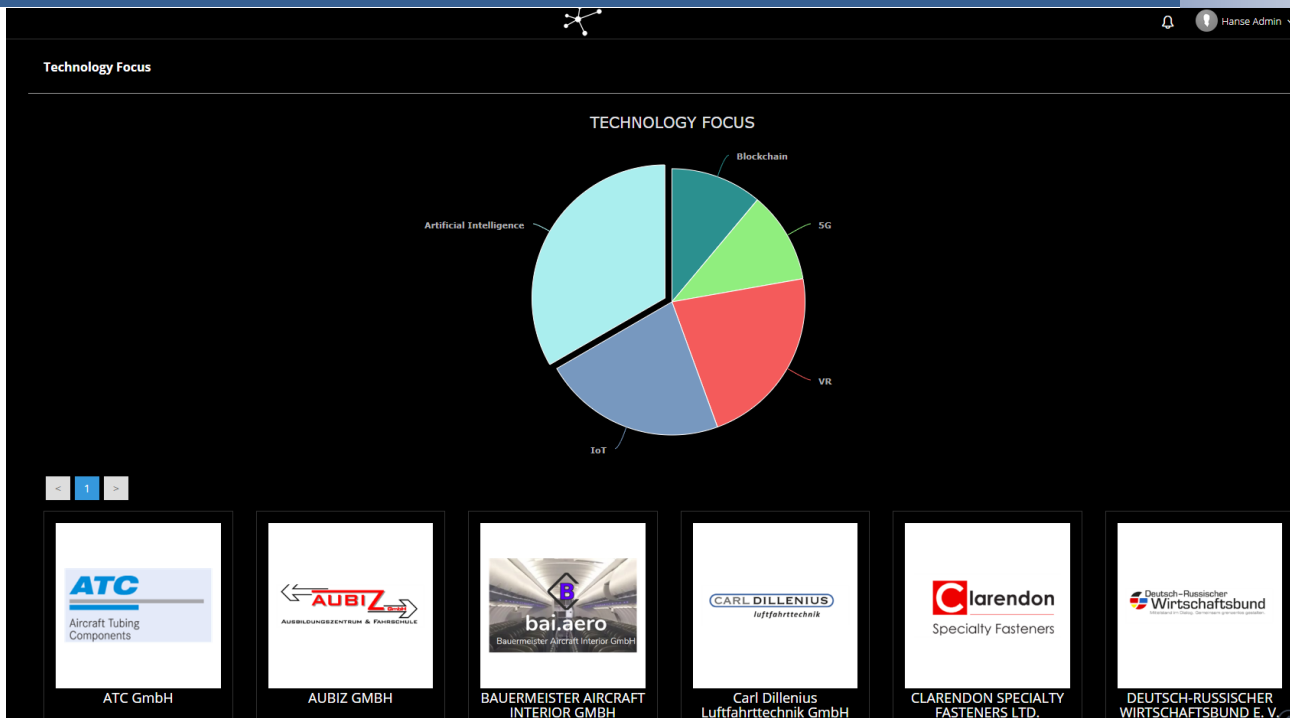

Figure 43. Interactive Reports in iQcluster Dashboard

**Data Sharing through iQcluster:** iQcluster does a great job of continuously mining intelligence from these networks and visualising them. As part of the wider EFPF ecosystem, iQcluster is sharing all this data back with EFPF ecosystem, through carefully designed APIs. This allows sharing of information continuously between the platforms. The API is called to write the data from iQcluster platform to the federated search index – Solr. This also provides greater flexibility to EFPF users who can access this intelligence directly from the ELK stack and combine it with other data sources to perform enhanced analysis.

### 2.4.2.3 Tendering and Bid Management

Tendering and Bid Management or Business Opportunity is a platform that will give SMEs a chance to offer their services for income generating opportunities. This will be achieved through three main service frameworks:

**Company Capability Directory:** To provide a directory of company profiles that will describe capabilities, services and accreditations that will enable the Tool to propose companies able to bid for a specific business opportunity based on the requirements of that opportunity. This framework will be able to query the Matchmaking Service within EFPF in order to be able to provide a broader scope of companies considered.

**Business Opportunity Board:** This framework will allow users to post Business Opportunities that can be viewed by other users of the system. The requirements for the opportunity can be defined including any mandatory skills or accreditations, other metrics such as quantity or capacity, whilst allowing the user to restrict access to certain fields until they grant access to them. In the Aerospace domain this is particularly important as privacy of data and procurement is particularly stringent.

**Messaging System** This will allow procurers to find prospective supplies and post opportunities direct to them without publishing them on the Opportunity Board. Similarly, with the Opportunity Board users can restrict access to certain fields until they grant

access to them as the intention to tender for the work becomes confirmed and trust between companies is established.

Within the functionality to search both the directory and business opportunities, we will offer insight for businesses on the current marketplace. Data will be gathered and represented, so that suppliers can see the requirements of procurers. For example, if procurers are regularly looking for suppliers that hold specific accreditations (i.e. QS 9000) suppliers will be able to make an informed decision on what is necessary for their business development. This will also offer the opportunity to observe the market and give the opportunity to win business better. There is also the potential to derive metrics in relation to trust and how companies reveal detail relating to business opportunities which will be considered at a later development stage.

To further show and explain how the Tender and Bid management platform please refer to the below images. 'Figure 44. Flow document outlining Tender & bid platform from specification document' which breaks down multiple different elements of the platform and how they will interlink. Along with 'Figure 45. Example of Tender & Bid Management platform business network intelligence' that shows the inputs and outputs from the platform.

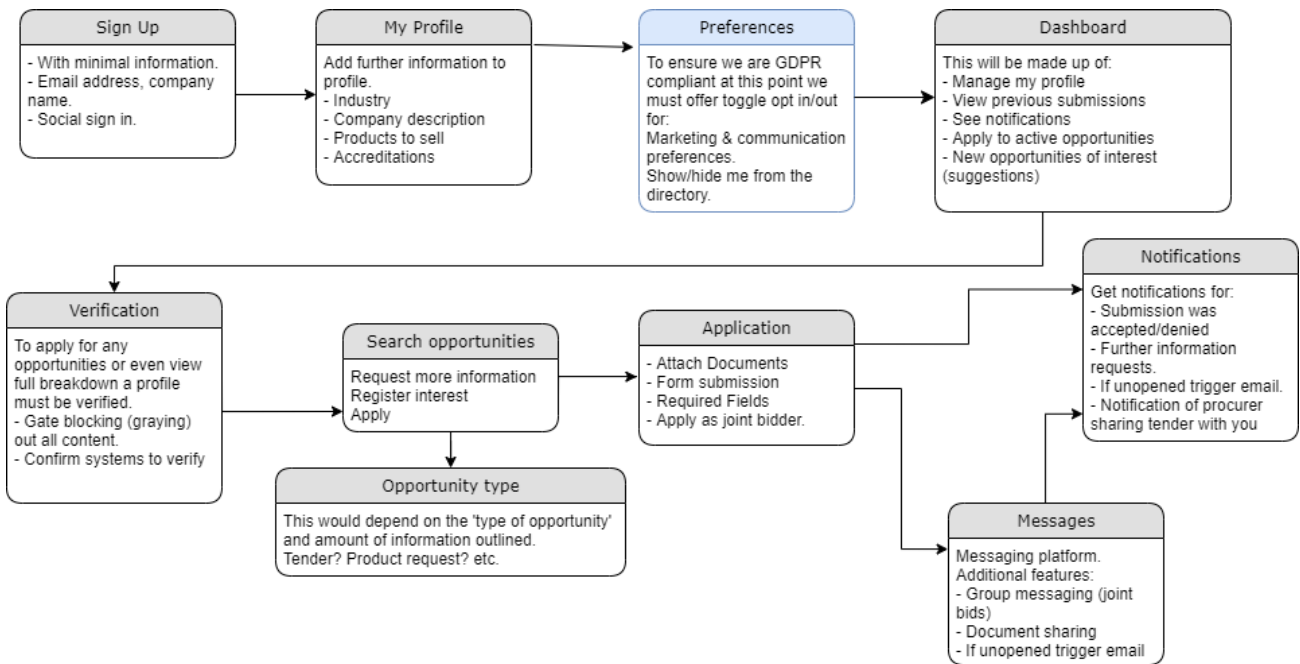

Figure 44. Flow document outlining Tender & bid platform from specification document

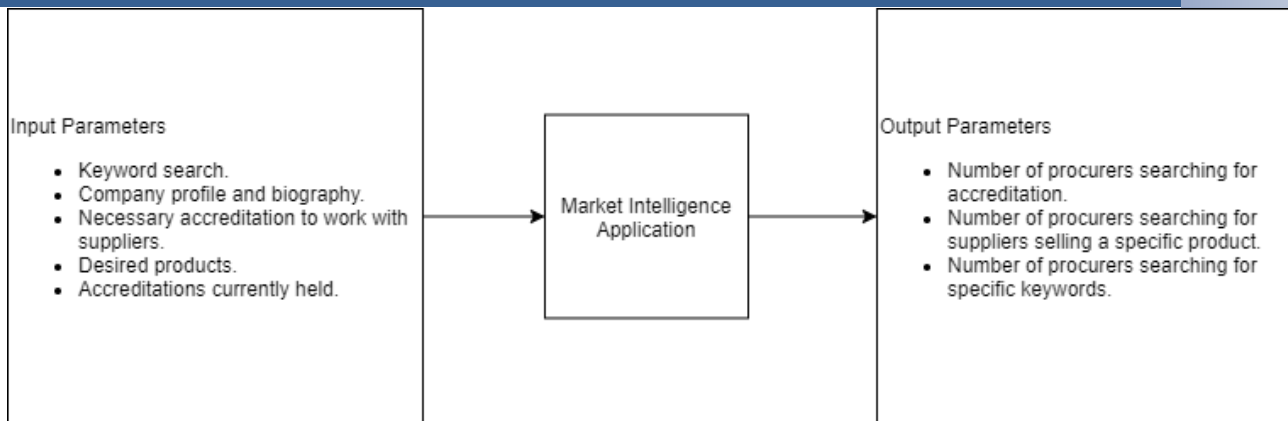

Figure 45. Example of Tender & Bid Management platform business network intelligence

### 2.4.3 Market Intelligence Services

Finally, for the residual factors that are not covered in internal workings and that of other connected companies through their network, a market intelligence tool is being introduced. This service aims to utilise advance data engineering and ML (machine learning) over openly available public data streams such as national company registers, websites, financial and credit rating databases etc. to provide an insight into the movements in market conditions.

The task partner VLC have proposed to introduce this standalone application directly onto the EFPF platform. While the development of this service is still in progress, this section will share the specifications and scope of this application.

**Motivation:** To leverage the openly available information on the web about other manufacturing companies and use it to profile them (prospects, competitors, potential customers etc.).

**Potential Application:** The intended application for the platform users could be to use this service to find potential customers and suppliers that they did not know of and to explore working with them to expand their business. Some other methods are being explored where a user could benefit from getting a demographic summary of the companies in a region for example, to understand ‘how many competitors or potential customers are in this region?’ and how I should ‘strategize to enter a strong growth sector with big presence in my region?’

**Scope:** The scope of this application includes all regions in the European Union. The data sources will include a list of national company registers open source manufacturing databases, certification and accreditation databases etc. A full list is being compiled right now and will be made available in the following report.

The tool is being designed to be completely GDPR (General Data Protection Regulation) compliant and does not collect, store or use any personal information in any way.

The focus is to keep the tool as generalised as possible and therefore a conscious decision is made to not focus on specific industries.

**SIPOC Diagram:** The specification review of this application is being held with task partner right now. Below are some sample screenshots from the specification document.

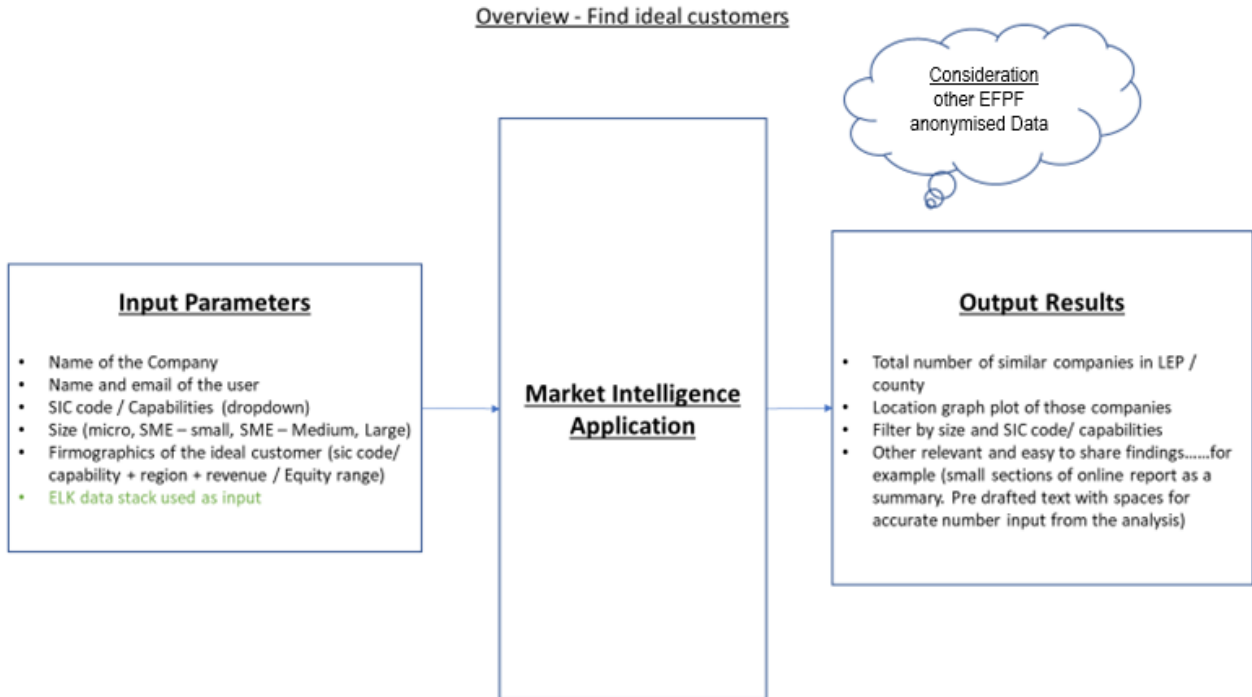

Figure 46. Sample SIPOC diagram from spec document – Market Intelligence Application

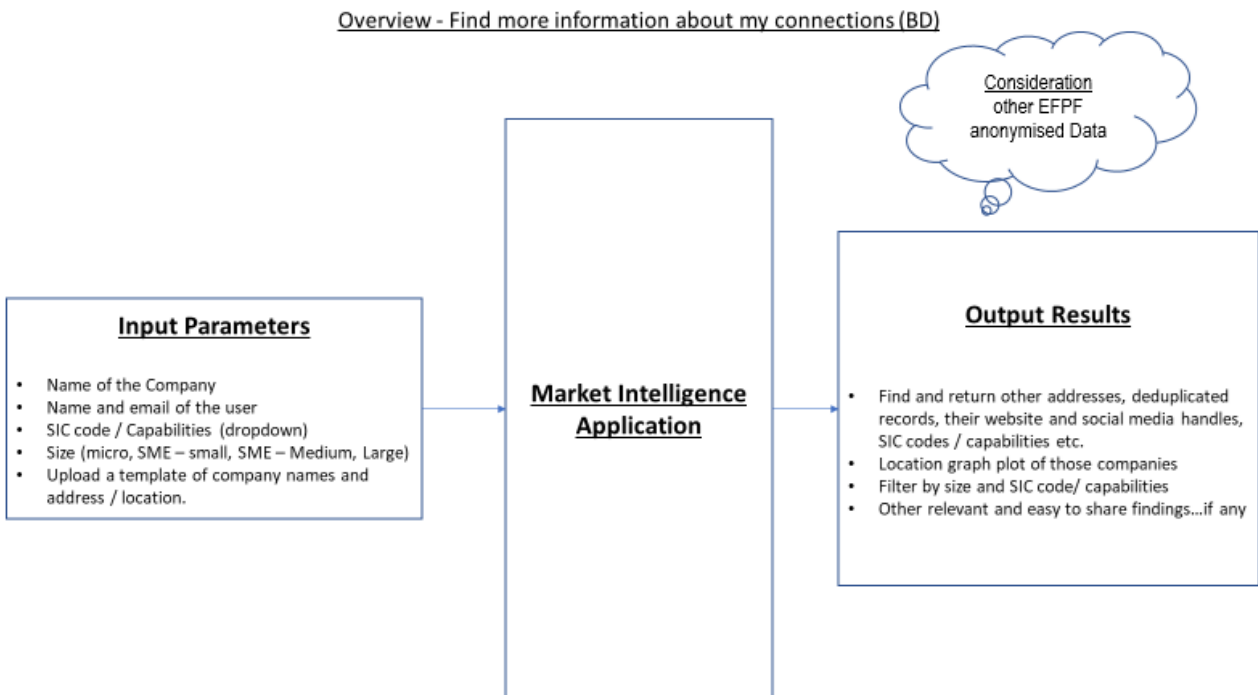

Figure 47. Sample SIPOC diagram from spec document – Market Intelligence Application

## 2.5 Execution and Pilot Case Studies

The task partners have decided that the best way to bring out the benefits of all solutions being offered under business and network intelligence, is to carry out pilots with our pilot partners. This is done with an aim to increase adoption of these tools amongst the consortium. Furthermore, it is believed that this will provide relatable case studies for users joining the platform through open calls and beyond. Therefore, we have engaged two pilots with our partners AIDIMME and HANSE AEROSPACE respectively.

### 2.5.1 Hanse Aerospace

As the largest independent association of suppliers and service providers in the aerospace industry, Hanse Aerospace connects small and medium-sized companies in Germany and around the world.

Hanse Aerospace currently has over 150 member companies with varied capabilities. It is a complex job to succinctly represent all the capabilities and ensure that each member gets relevant exposure to prospective clients.

Therefore, Hanse Aerospace have adopted iQcluster platform offered through the EFPF Platform to achieve following results:

**All Legacy information compiled together:** Hanse Aerospace have collected information from their membership for a number of years. This information relates to understanding their capabilities, previous projects, current and future customers, etc.

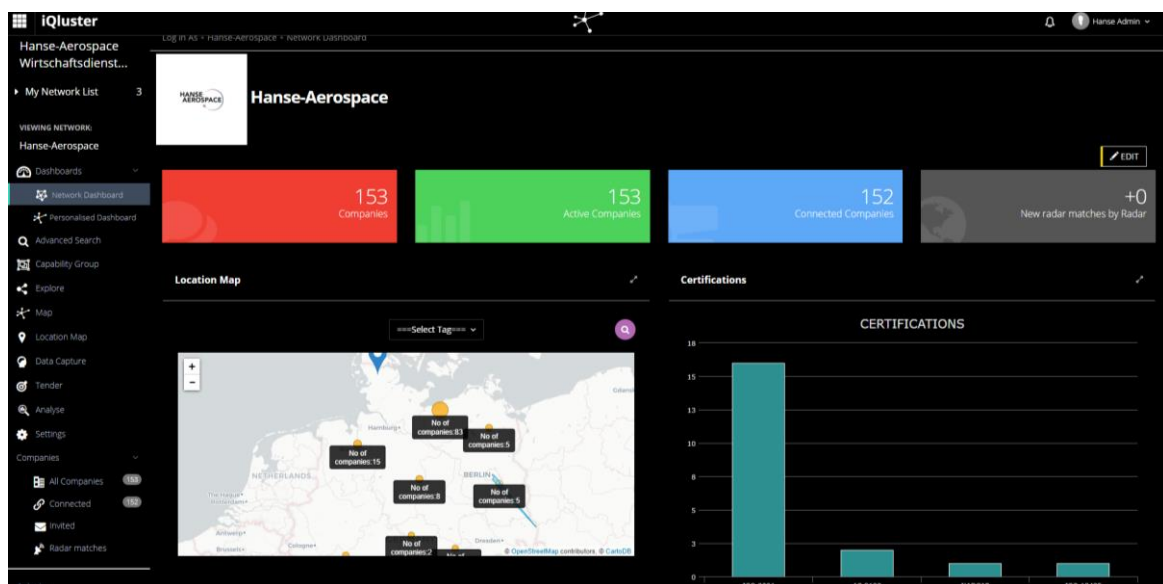

Figure 48. Hanse Aerospace network dashboard

Traditionally, for any industry association, this information sits in a combination of spreadsheets, emails and other survey tools.

By adopting iQcluster, Hanse Aerospace are able to onboard as much of that information as they would like. iQcluster then serves as a central repository which is much more powerful as it allows them to not only store all this data together, but also report on it. This is great for both the leader (Hanse Aerospace) as well as the member companies who now have access to curated reports and charts that are useful.

This also shifts the information flow from a traditional 'one-to-many' approach where the members submit their information but get nothing back in response, to a 'many-to-many'



approach where the members can access these reports and chart analysis from the data that they have contributed to over the years. A snapshot of Hanse Aerospace’s network dashboard is presented in Figure 48.

### Gathering open source information

Getting information from the companies through lengthy forms and email chains is cumbersome. Hanse Aerospace are using iQcluster platform’s intelligence gathering services to scrape openly available information about their member on web. This gets fed back into Hanse Aerospace’s network and enhances the decision-making data available at their disposal.

Sometimes, it also brings out a more complete picture of their members as some companies only supply ‘Aerospace related’ information to them as they are an aerospace association. However, it is useful to understand the breadth of capabilities of a member company so that they can be linked to relevant opportunities beyond the Aerospace sector. A screenshot of ‘Advanced Search’ screen in iQcluster which uses the openly scraped information along with existing uploaded data to match with search criteria is show in figure 49.

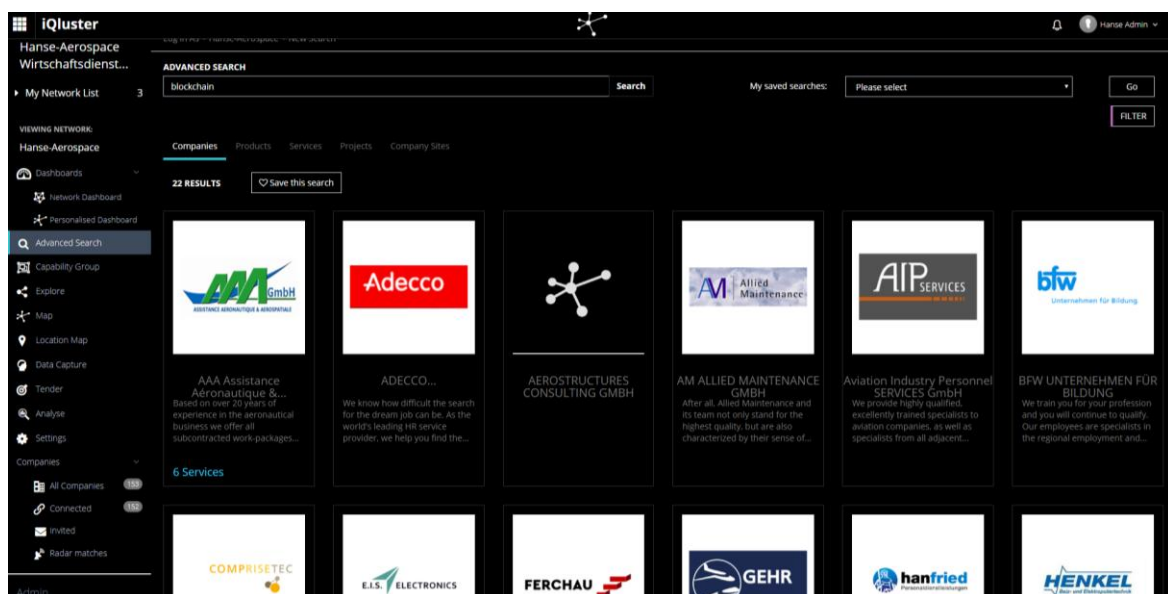

Figure 49. Advanced Search screen in Hanse Aerospace pilot network

**Website Integration:** While this is a great way to build up intelligence about your network, it is important to understand that this is available only to active members who log in using their license credentials. For Hanse Aerospace, a lot of the prospective customers and collaborators will be new (so there is no way to know of them in advance and cannot be given access to portal ahead of time); they will be visiting the website (in search of contact details and member listings); they will have a few starting questions/preferences (for example, ‘the company should have capabilities in manufacturing Titanium parts’ or they must have been ‘certified by an OEM such as Boeing’ already). A lot of this information is already collected, curated and analysed by Hanse Aerospace already on iQcluster platform.

Therefore, they decided to use 2 step integration process of their network’s ‘Explore Map’ on to their website. This allowed their traffic to not only view member companies but also gave them the freedom to drill down into the network by capabilities, accreditations, technologies etc. (essentially all the prerequisites that their prospective clients or collaborators will be looking for) and find member companies of interest.



Individual members have and maintain their own profiles, so they have the freedom to upload and update as much relevant information as they would like to share. Hanse Aerospace believe that this has helped them extract important information out of this tool and make it available to outside the platform to key stakeholders through their website iframe integration. A screenshot of Hanse Aerospace’s website with embedded iQcluster map is shown in figure 50. The same page can be accessed through this link - <https://www.hanse-aerospace.net/de/ueber-uns/mitglieder>.

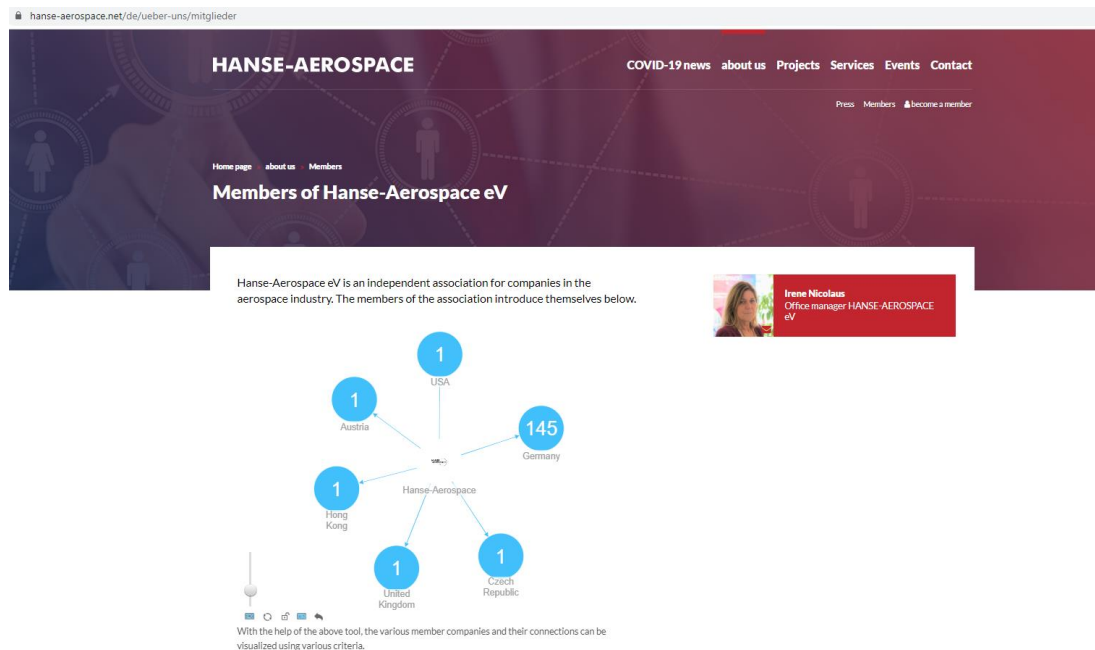

Figure 50. iQcluster Explore Map integrated into Hanse Aerospace’s public website

**Next Steps:** While this has already delivered great benefits for Hanse Aerospace with respect to collection, modelling and dissemination of intelligence, there are concrete next steps that have been planned in order to enhance the current status.

The immediate next step is to use the already generated momentum to encourage all of the members to use this service and maintain their up to date profile. This will enable them to appear higher up when searched and also allow them to have a strict quality control over information about their work.

Once most members are online and connected through the platform, Hanse Aerospace will be able to conduct technology audits, surveys and questionnaires all through the iQcluster platform. This will save up the added cost of using a third-party tool, extracting the results and analysing them separately before embedding them into a static PowerPoint. Instead this will allow Hanse Aerospace to build scored surveys that will populate the dynamic charts as the companies fill in their answers in real time.

Ambition is to extend this to digital onboarding of new members. Such that the new companies will not have to fill out separate forms and sheets over email. They can be sent a link which allows them to directly fill in their details and get onboarded to the online network.

A couple of steps further into the future are using

- Tender functionality to release RFQs (Request for quotation) to the member population and receive their responses through this platform.

- Enabling cluster to cluster connectivity which will link Hanse Aerospace membership directly to other associations across Europe who adopt the EFPF platform.

## 2.5.2 AIDIMME

The pilot case study for AIDIMME is addressing a specific Innovation clusters called **AEI** (*Agrupación Empresarial Innovadora* – Innovative Business Association) aiming to improve the competitiveness of small and medium-sized enterprises in the Wood & Furniture domain. To this end, it plans to support with public resources the innovation and business competitiveness strategies developed by the AEI that are recognized as such as a result of their registration in the Registry of Innovative Business Groups of the Spanish Ministry of Industry. AIDIMME aims to use the iQcluster platform as well as other EFPF intelligence services to realise this pilot.

**Industrial cluster scope:** Wood & Furniture Innovation Cluster in the Valencian region (Spain).

**Description of the cluster <sup>1</sup>:** Around **260 private firms** in the Valencia region operating in the manufacturing of wood-derived products (wood-boards, flooring, facing, etc.), home and contract furniture (living room, bedroom, bathroom, kitchen, office, retail, etc.), services (installations, refurbishment, etc.) and related ancillary industries (components, fittings, coatings, etc.)

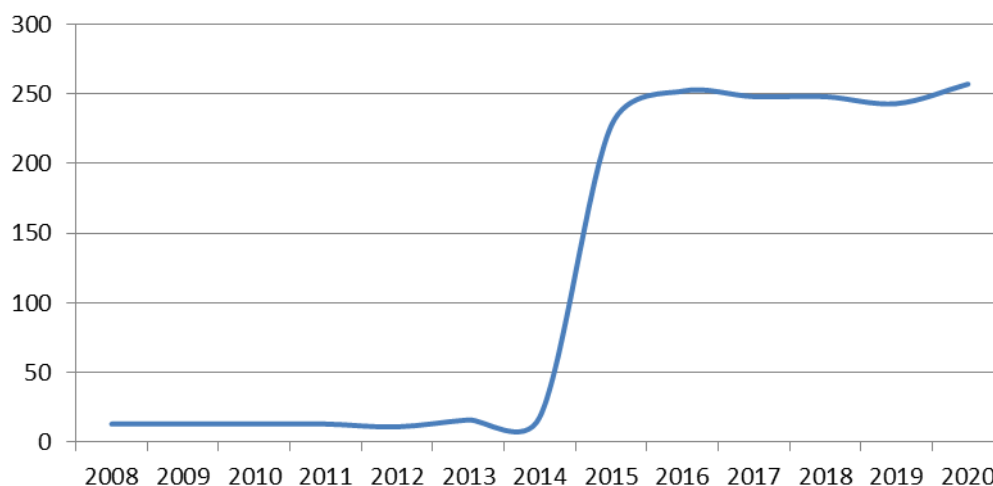

Figure 51. Evolution of Wood & Furniture Innovation Cluster

Main activities of the Wood & Furniture innovation cluster are related to furniture manufacturing, wood and cork industries, metal products, wholesaling and industrial association activities.

<sup>1</sup> <https://clusters.ipyme.org/es-es/PoliticaClusters/Informacion/Paginas/QueEsCluster.aspx>

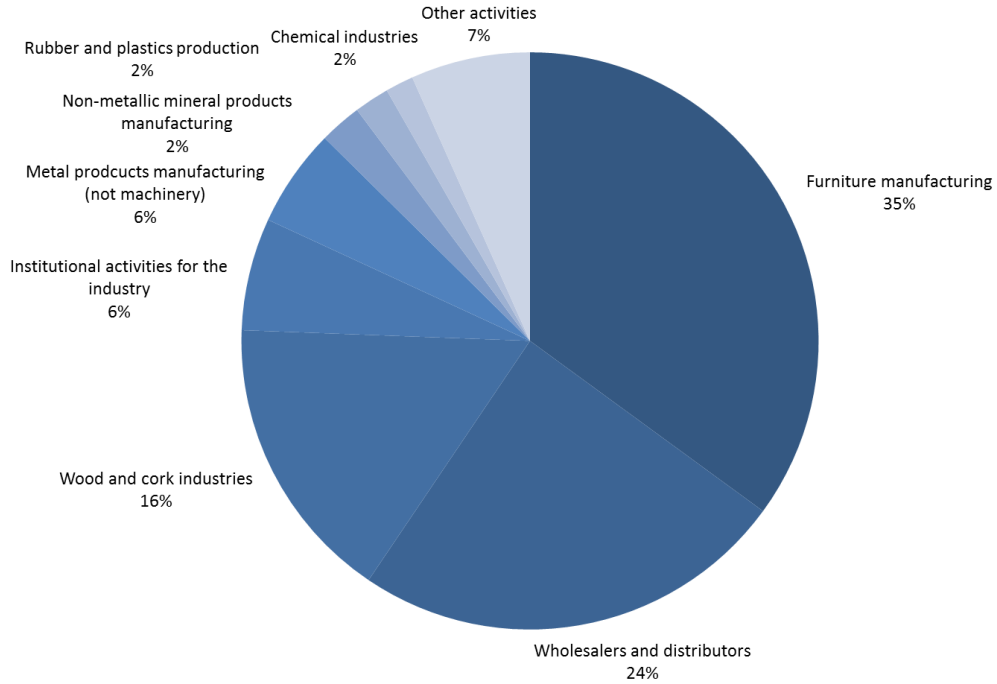

Figure 52. Main Industrial activities in the cluster

Most of companies within the innovation cluster are SME, what has a direct effect on the distribution of income in the cluster: a few large companies represent an important part of the market, with a Gini index of around 0,6.

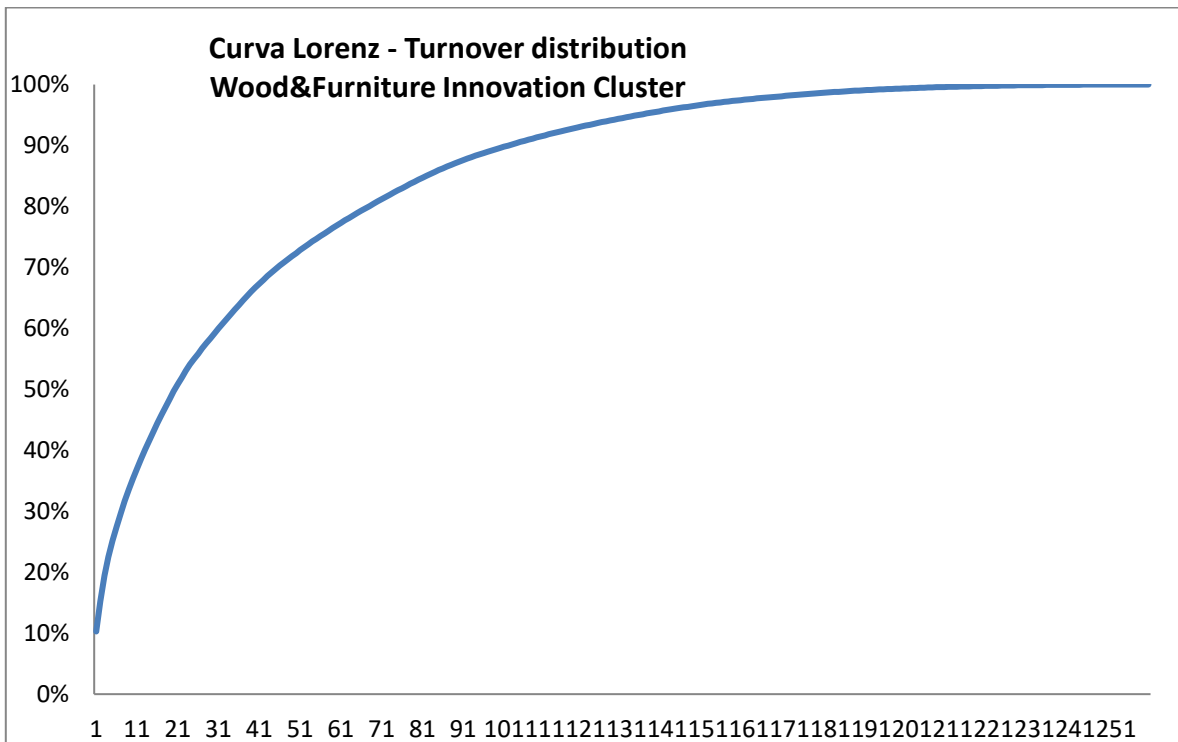

Figure 53. Turnover distribution of the Innovation cluster

**Objective:** Create an analytic tool for specific data collection and treatment on innovation issues related to the wood & furniture industrial cluster in the Valencian region.

### Value proposal for firms (potential users) in EFPF:

- Monitor the activity of the wood & furniture innovation network in Valencian region (number of companies, main projects, localisation, etc.).
- Access to exclusive cluster firms' data on R+D and innovation issues.
- Identify and contact potential partners in the wood & furniture industry cluster for B2B exchanges (purchase, sell, collaborate, etc.).
- Identify focal players in the industry for key innovation variables (e.g. which is the company leading or taking part in most of innovation projects in the industry?).
- Compare the firm's position in relation to the rest of the industry (e.g. how important is my company in the industry in terms of number of innovation projects?).
- All these points through a friendly intuitive front-end with visual information (no complex log in process or interaction within the platform) would be great for the industrial companies.

### Expected Functionalities

- **Cluster management:** basic firm data as turnover, employees, location, participation in b2bmarketplace, and description of activity and CNAE (National Classification of Economic Activities) code.
- **Data collection (three domains):**
  - I. **Innovation activity with AIDIMME** (i.e. number of R&D and innovation projects, euros spent, variety per department, funding programmes, associates to AIDIMME, participants in other industrial groups – Market Observatory, for example) → This data is introduced in iQluster by AIDIMME and could be translated into standard indicators so confidential firm's data is not published (for example, a scale for measuring level of innovation from 0 to 10).
  - II. **Innovation management in firms** (i.e. co-creation practices, 5 top innovative suppliers, 5 top innovative clients, number of employees dedicated to R&D+i, annual budget, external collaborators, etc.) → This data is gathered from companies.
  - III. **Emerging innovation issues** (i.e. measuring interest in Circular Economy, industrial symbiosis, Industry 4.0, Big Data, Artificial Intelligence, Machine Learning, Internet of Things, Business Intelligence, etc.). → This data is gathered from companies.
- **Analytics & Reporting:** create accessible charts information for companies.
- **Cluster mapping:** iQluster should represent the following conceptual cluster maps:
  - I. **Innovation supply chain** in the cluster (B2B flows within the cluster: represent upstream (providers) and downstream (clients) connections between firms at a cluster level.
  - II. **Focal companies** that are in contact with most of suppliers or clients, so they act as focal innovators in the industry.
  - III. **Value networks** created around main companies that pull the **ancillary industry** for wood & furniture in Valencian region.

Example of expected cluster mapping with identification of a **focal firm** and related innovative ecosystems:

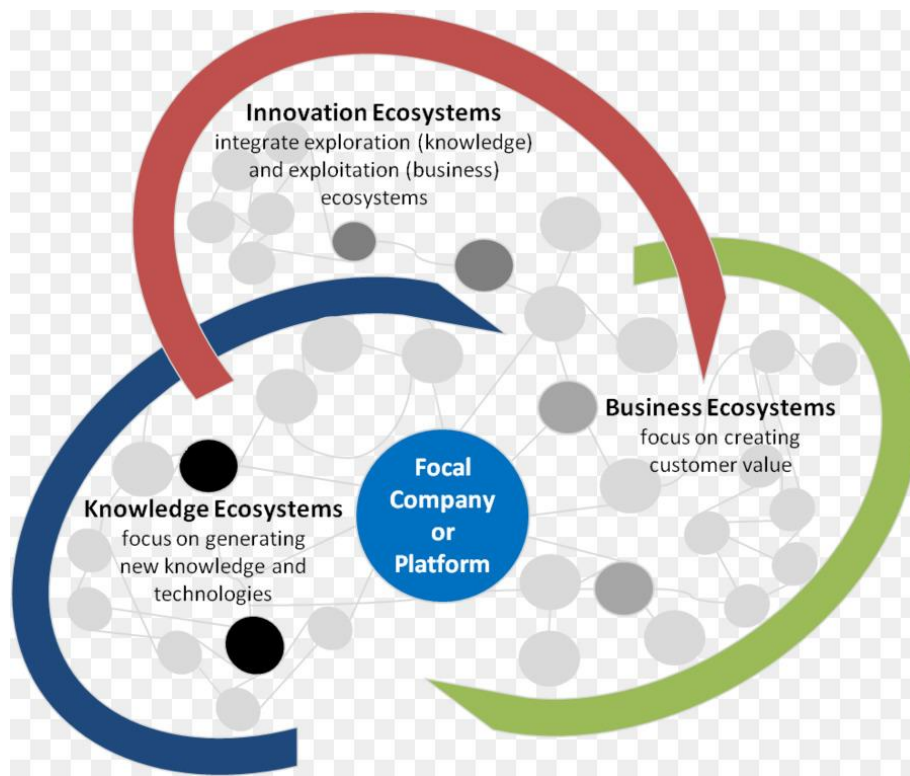

Figure 54. Focal Company mapping

**Proposed roadmap for demo stage:** Figure 55 shows the different steps for the agreement framework. It is necessary to create such a framework both internal among the members of the consortia, and with the companies that are part of the cluster. A framework that will define the services, the confidentiality of the input data, the scope and the conditions over which the project is established. Information gathering: both secondary — Commercial Registry information, activities, — and primary. With the information gathered, we can establish an example demo:

- Questionnaire creation, and data gathering.
- Data analysis. Definition of what we want to show.
- Visualization of the results through an interactive dashboard.
- Dissemination of the results to the companies.

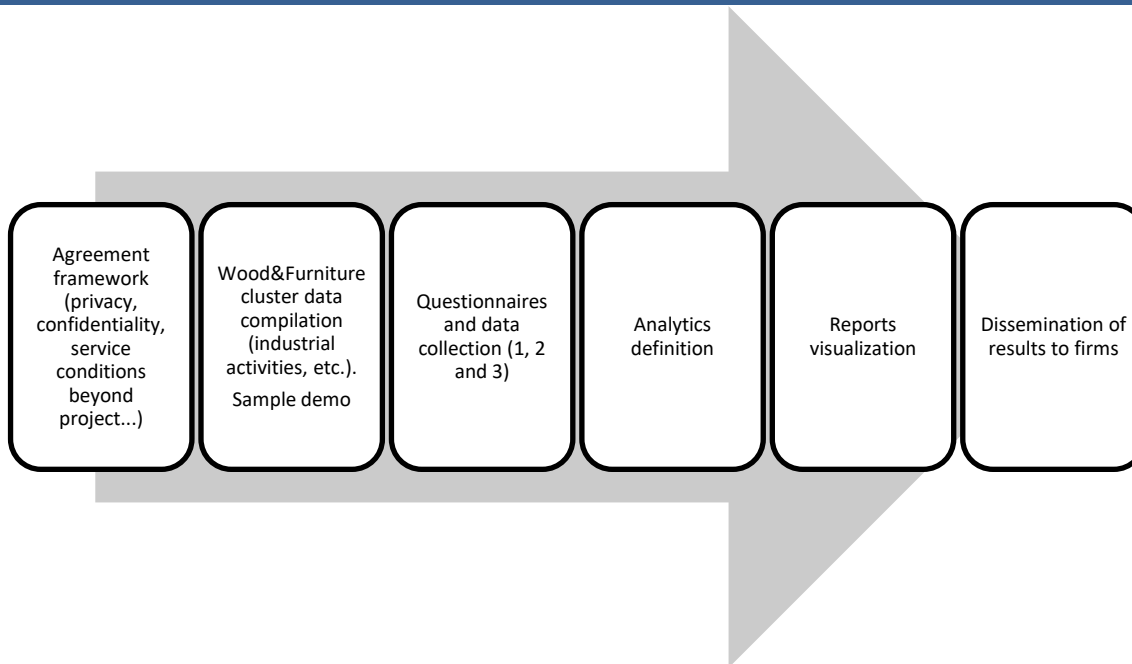

Figure 55. Proposed roadmap for engagement steps to realise this pilot case study

## 2.6 Limitations

Biggest limitation of business intelligence and its widespread adoption is the lack of awareness and understanding of these systems amongst small and medium sized companies. This is new to smaller companies who aren't digitally aligned and do not have the necessary infrastructure in place to leverage its benefits. Prerequisite to generating intelligence is the availability of raw data in digital format. Most SMEs do not have the systems to capture and store this data in appropriate format necessary. For those that do have this infrastructure, data security and sensitivity concerns prevent them from adopting these (mostly cloud based) solutions.

There is certainly a cultural barrier too. Especially with older workers, which is a challenge for today's organisations due to workforce shrinking and ageing (Ewa Soja, Piotr Soja, 2020). Digital technology has made rapid advancements in recent years. While the younger generations have embraced it, the older generations, a big majority of whom work in manufacturing sector) resist this change in traditional ways. This makes it difficult for business owners to introduce even basic data capture which are only pre-requisite to more advanced intelligence generating modules.

Therefore, a considerable effort for digital advocates goes into educating the manufacturing businesses about benefits of generating intelligence from their internal systems and their network.

With a unified access to central data spine as well as connected tools, services and platform, EFPF aims to lower these barriers and promote adoption of intelligent digital systems in European manufacturing ecosystem.

## 2.7 Further Developments

Planned further developments will continue beyond M18 of the project. A short description explaining next steps is provided in sections below:

## **2.7.1 Intracompany Level Intelligence Services**

Pilot partners are being engaged to use and demonstrate benefits of intracompany intelligence modules.

## **2.7.2 Platform & Network Level Intelligence Services**

### **2.7.2.1 Platform & Network Intelligence Solution**

At this stage in the development of the platform and network intelligence solution, the data is currently collected through a direct connection to the data source. The next steps for this solution will be to reconfigure the ingestion of data to flow through the EFPF data spine. Alongside this, collaboration will also take place with the projects user partners to discover and identify more tailored insights of trends within the market, that can provide value to their organisations.

### **2.7.2.2 iQluster Platform**

Task partner VLC have an internal roadmap to continuously develop iQluster platform and introduce features that will help wider adoption such as mobile application and messaging service.

Moreover, a second release of the API (sharing collected intelligence on companies back to EFPF portal) is scheduled for PR4 sprint. the second release will pass on more information such as a company's supply chain connections mapped on iQluster platform, amongst others.

### **2.7.2.3 Tendering and Bid Management**

The tendering and bid management tool will cater for requirements in Aerospace and Furniture domains, but is envisaged to be applicable to any domain. The users for both domains have been involved in the prototype proposals and the road map for the tools is to develop a prototype offering the three main feature sets of Company Capability Directory, Business Opportunity Board and Messaging System in order for the Pilot partners to evaluate. Once feedback has been gathered during this prototype pilot the finalised second release will be made available. This will be before the end of the pilot timescale in order to get valuable business and network intelligence from its use.

## **2.7.3 Market Intelligence Services**

The specification document has passed critical phase one review and scheduled for a second review with involved partners. The development of this application Market Intelligence service is planned for Q3, 2020. The partners hope to make significant progress before the M18 review scheduled for September, 2020. Beyond that milestone, the aim is to build up the application to a state where it can be used for open calls, which are commencing soon.



### 3 Conclusion

This report shows an innovative approach to combining federated search, recommendation systems and agent based automated matchmaking systems to improve user experience, increase user engagement through incentives and rewards mechanisms, boost conversion rates and operationalisation of businesses to the connected platform companies and their products and services through EFPF ecosystem. It discusses the current design and implementation of matchmaking functionality in EFPF and its relationship with Business & Network Intelligence components. The data captured in the EFPF portal's federated search and matchmaking components are effectively utilised in BNI to generate valuable platform and market intelligence in EFPF ecosystem. The two components complement each other as matchmaking generates logs of user journey which is utilised by Business and Network Intelligence components (as well as other BNI tools capture and share intelligence back with the ecosystem) which in turn helps in better matchmaking and the cycle continually improves over time.

Some of the key benefits of implementing federated search and recommendation systems can be summarized as follows (Algolia, 2019) (Melton and Buxton, 2006):

- It is an efficient way for searching through multiple sources and a larger volume of information, which results in getting more accurate results and improving overall user experience within EFPF in finding the most suitable service providers/partners and products & services;
- It increases the relevance of search results by using different parameters to rank different types of content;
- It requires to maintain only one search engine for several platforms and a variety of their data sources, which improves reliability and security;
- It ensures that the content of new platforms that join a platform ecosystem, is early integrated into existing federated search and recommendation services.

Some key benefits of Business and Network Intelligence solutions in the context of EFPF are summarised below:

- Business are able to use a range of web-based applications that help them collect, analyse and derive intelligence from their internal operations through a single portal without having to spend on complex implementations and vendor lock in.
- Manufacturers can utilise tools available to help them connect, visualise and mine intelligence from their supply chains digitally, while promoting digital uptake throughout the value chain.
- Platform users can utilise network intelligence to understand demand and trends across Europe through the EFPF ecosystem and position their business accordingly.
- Provides an opportunity to generate meaningful intelligence from the user behaviour of the connected manufacturing community across Europe.

However, there are still many questions to be explored in the intersection of these fields:

- Which recommendation algorithms are more suitable for federated digital environments?

- How to reduce the negative impact of the performances of recommendation systems due to incomplete and/ or missing data?
- What is the minimum amount of data to run an effective recommendation system?
- How symbolic AI methods can compensate for the missing data and support recommendation systems?
- How can ML (machine learning models) help in aggregated procurement opportunities for companies on the platform?

## Annex A: History

Document History	
<b>Versions</b>	<p>V0.95:</p> <ul style="list-style-type: none"> <li>• Report sent to internal reviewers</li> </ul> <p>V0.9:</p> <ul style="list-style-type: none"> <li>• Issues corrected, document structure formalised and report prepared for internal review.</li> </ul> <p>V0.1 – V0.8:</p> <ul style="list-style-type: none"> <li>• Collection of contributions from partners. Curation of the report and refining of the document flow</li> </ul>
<b>Contributions</b>	<p>AID:</p> <ul style="list-style-type: none"> <li>• Vicente Sales</li> <li>• Núñez Ariño, María José</li> </ul> <p>ICE:</p> <ul style="list-style-type: none"> <li>• Ross Campbell</li> </ul> <p>SRFG:</p> <ul style="list-style-type: none"> <li>• Violeta Damjanovic-Behrendt</li> <li>• Dileepa Jayakody</li> </ul> <p>CERTH:</p> <ul style="list-style-type: none"> <li>• Alexandros Nizamis</li> <li>• Vaia Rousopoulou</li> </ul> <p>VLC:</p> <ul style="list-style-type: none"> <li>• Happy Dudee</li> </ul> <p>C2K:</p> <ul style="list-style-type: none"> <li>• Simon Osborne</li> <li>• Bethan Wright</li> </ul>

## Annex B: References

- A.C.Elguindi and K. Schmidt (2012). "Discovery systems, layers and tools, and the role of the electronic resources librarian". In *Electronic Resource Management. Practical Perspectives in a New Technical Services Model*. pp: 109-139. Chandos Information Professional Series. DoI: <https://doi.org/10.1016/B978-1-84334-668-5.50004-3>
- M. Taylor (2006). "Using the Google Search Appliance for federated searching", *Internet Reference Services Quarterly*, 10(3): 45–55.
- R. Cooke and R. Donlan, (2008). "Thinking inside the box: comparing federated search results from Google Scholar, Live Search Academic, and Central Search", *Journal of Library Administration*, 46(3/4): 31–42.
- Orchilles, J. (2010). Introduction to Windows 7. Microsoft Windows 7 Administrator's Reference, 1–91. doi:10.1016/b978-1-59749-561-5.00001-2
- J. Melton and S. Buxton (2006). "Finding Stuff", In *The Morgan Kaufmann Series in Data Management Systems, Querying XML*, Morgan Kaufmann, pp. 623-645, ISBN 9781558607118.
- L.B. Mullen, (2010). Public services work and open access. *Open Access and the Academic Librarian: Its Relevance for Everyday*. In *Open Access and its Practical Impact on the Work of Academic Librarians*. pp. 147-179.
- Xu, Fei. (2009). Implementation of a Federated Search System: Resource Accessibility Issues. *Serials Review - SER REV*. 35. 235-241. 10.1016/j.serrev.2009.08.019.
- D. Fryer, (2004). "Federated Search," *Online* 28, no. 2. pp: 16–19.
- R. Tang, I. Hsieh-Yee and S. Zhang, (2007). "User Perceptions of MetaLib Combined Search: An Investigation of How Users Make Sense of Federated Searching," *Internet Reference Services Quarterly* 12, no. ½. Pp: 211–236.
- D.G. Dorner and A.M. Curtis, (2004). "A Comparative Review of Common User Interface Products," *Library Hi Tech* 22, no. 2, pp: 182–197.
- B. Gerrity, T. Lyman and E. Tallent, (2002). "Blurring Services and Resources: Boston College's Implementation of MetaLib and SFX," *Reference Services Review* 30, no. 3, pp: 229–241.
- L.S. Mestre, C. Turner, B. Lang and B. Morgan, (2007). "Do We Step Together, in the Same Direction, at the Same Time? How a Consortium Approached a Federated Search Implementation," *Internet Reference Services Quarterly* 12, no. 1/2, pp: 111–132.
- L. Fancher, (2007). "Wanted, Dead or Alive: Federated Searching for a Statewide Virtual Library," *Internet Reference Services Quarterly* 12, no. 1/2, pp: 133–158.
- K. Calhoun, (2005). "An Integrated Framework for Discovering Digital Library Collections," *Journal of Zhejiang University Science* 6A, no. 11, pp: 1318–1326.
- E. Tallent, (2004). "Meta-searching in Boston College Libraries — a Case Study of User Reactions," *New Library World* 105, no. 1/2, pp: 69–75.
- Algolia, (2019). What is Federated Search? URL: <https://blog.algolia.com/what-is-federated-search/> Last accessed: January 2020.

R. Baeza-Yates and B. Ribeiro-Neto. Modern Information Retrieval. Addison Wesley, New York, USA, II edition, 2010.

Apache Jena, (2018) , Retrieved from JENA: <https://jena.apache.org/documentation/inference/>

T.L. Saaty, (1994), Fundamentals of Decision Making and Priority Theory with the AHP, RWS Publications, Pittsburgh, PA, U.S.A

V. Belton and T. Gear ,(1983) "On a short-coming of Saaty's method of analytic hierarchies," Omega, 228-230.

P.C. Fishburn, (1967) ,Additive Utilities with Incomplete Product Set: Applications to Priorities and Assignments, Operations Research Society of America (ORSA) Publication, Baltimore, MD, 1967.

FITMAN-SeMa, (2018), Retrieved from <http://www.ware4industry.com/?portfolio=metadata-and-ontologies-semantic-matching-sema/>

FIWARE, (2018), Retrieved from FIWARE: [http://www.\\_ware4industry.com/](http://www._ware4industry.com/)

M. Nodine, J. Fowler, T. Ksiezyk, B. Perry, M. Taylor, and A. Unruh (2000). Active information gathering in InfoSleuth. International Journal of Cooperative Information Systems, 9(1/2)

K. Arisha, F. Ozcan, R. Ross, S. Kraus and V. S. Subrahmanian,(1998) "IMPACT: the interactive Maryland platform for agents collaborating together," Proceedings International Conference on Multi Agent Systems (Cat. No.98EX160), Paris, France, pp. 385-386, doi: 10.1109/ICMAS.1998.699225.

A. Idrees, (2015). Towards an automated evaluation approach for e-procurement. 67-71. 10.1109/ICTKE.2015.7368473.

Supplier PartyType (2013), Retrieved from datypic : [http://www.datypic.com/sc/ubl21/t-cac\\_SupplierPartyType.html](http://www.datypic.com/sc/ubl21/t-cac_SupplierPartyType.html)

CatalogueType (2013), Retrieved from datypic : [http://www.datypic.com/sc/ubl21/ns11\\_CatalogueType.html](http://www.datypic.com/sc/ubl21/ns11_CatalogueType.html)

Zhelyu Vladimirov (2017), The EU industrial policy and SME development in Central and Eastern Europe

R. F. v. d. Lans, Data Virtualization for Business Intelligence Systems, 1st ed., US: Morgan Kaufmann Publishers Inc, 2012.

E. K. Thorpe, "What is Network Intelligence?," 2019. [Online]. Available: <https://www.itpro.co.uk/network-internet/31914/what-is-network-intelligence>. [Accessed 14th May 2020].

Soja, E. and Soja, P. (2020), "Fostering ICT use by older workers: Lessons from perceptions of barriers to enterprise system adoption", Journal of Enterprise Information Management, Vol. 33 No. 2, pp. 407-434. <https://doi.org/10.1108/JEIM-12-2018-0282>



# European Factory Platform

[www.efpf.org](http://www.efpf.org)